

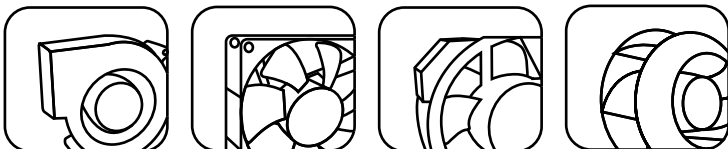

## AC Axial Fan

***CROWN PELECTRONICS***

● PRODUCT FLOW LINE

















<http://www.crownelectronics.com.tw>

**Ver.02**

# CROWN

## AC Axial Fan

Frame size	Air flow (CFM)	20	40	60	80	100	200	400	600	800
□ 80mm			 25mm  38mm							
□ 92mm			 25mm  38mm							
□ 120mm				 25mm  38mm						
□ 172mm							 51mm			
□ 180mm								 65mm		
□ 205mm									 72mm	
∅ 254mm										 89mm

### Application

Machine ventilator  
Home appliance  
Ventilator

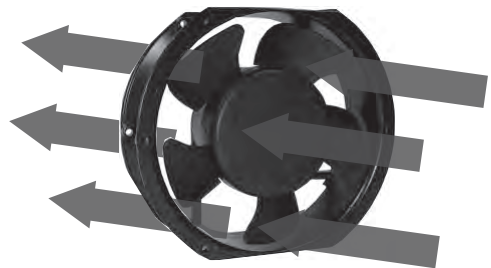
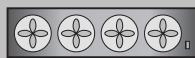

# 80

## IGE Series

### Size (尺寸) 80\*80\*25 mm

#### General Specifications (一般規格)

- ★ Motor : Shaded pole AC motor    ★ 馬達 / 交流蔽極式馬達
- ★ Frame : Aluminum                    ★ 材料 / 框 : 鋁
- ★ Impeller : Plastic (94V-0)        ★ 材料 / 葉 : 塑膠 (94V-0)
- ★ Bearing : Ball; Sleeve Bearing   ★ 軸承 / 滾珠; 含油軸承
- ★ Weight : 0.26 Kg                   ★ 重量 / 0.26 公斤



#### Major Characteristic Parameters

Model	Bearing System	Rated Voltage	Freq.	Input Power	Rated Speed	Maximum Air Flow		Maximum Static Pressure		Sound Level	Weight
						m3/min	CFM	mm-H2O	in-H2O		
IGE08025_1H	B S	115	50 / 60	13 / 11	2500 / 3000	0.62 / 0.71	22.0 / 25.0	4.5 / 5.3	0.18 / 0.21	28 / 29	0.26
IGE08025_2H	B S	230	50 / 60	13 / 11	2500 / 3000	0.62 / 0.71	22.0 / 25.0	4.5 / 5.3	0.18 / 0.21	28 / 29	0.26

\*All reading are typical values at rated voltage

\*Specifications are subject to change without notice

\* Bearing system B: Two Ball Bearing S: Sleeve Bearing

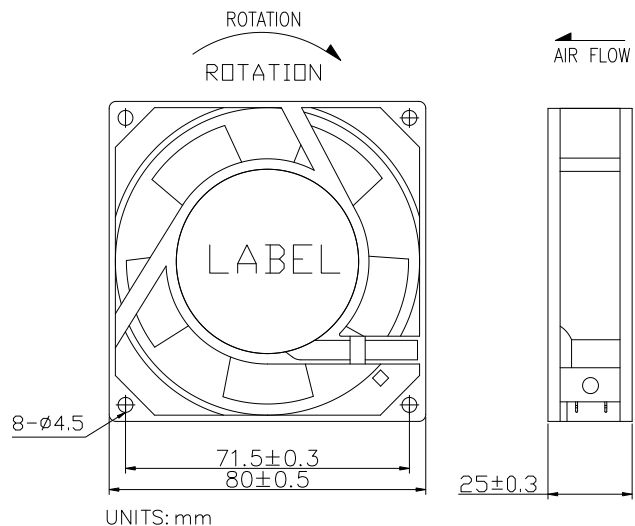
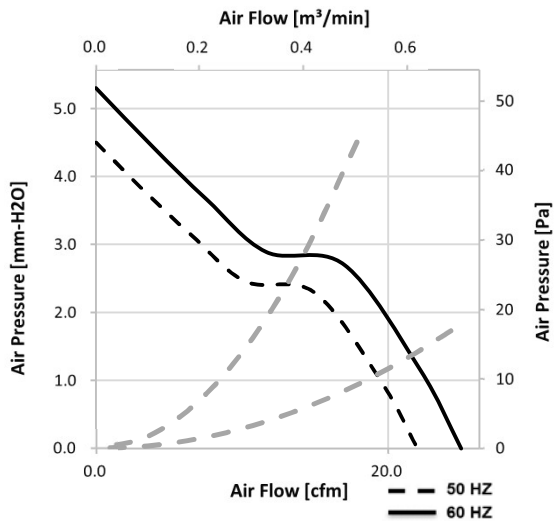

www.crownelectronics.com.tw



# 80

## IGE Series

Size (尺寸) 80\*80\*38 mm

### General Specifications (一般規格)

- ★ Motor : Shaded pole AC motor.   ★ 馬達 / 交流蔽極式馬達
- ★ Frame : Aluminum                   ★ 材料 / 框 : 鋁
- ★ Impeller : Plastic (94V-0)       ★ 材料 / 葉 : 塑膠 (94V-0)
- ★ Bearing : Ball;Sleeve Bearing   ★ 軸承 / 滾珠;含油軸承
- ★ Weight : 0.37 Kg                 ★ 重量 / 0.37 公斤



### Major Characteristic Parameters

Model	Bearing System	Rated Voltage	Freq.	Input Power	Rated Speed	Maximum Air Flow		Maximum Static Pressure		Sound Level	Weight
						m3/min	CFM	mm-H2O	in-H2O		
IGE08038_1H	B S	110	50 / 60	14 / 11	2450 / 2950	0.74 / 0.88	26 / 31	4.3 / 6.0	0.17 / 0.24	26 / 30	0.37
IGE08038_2H	B S	230	50 / 60	14 / 11	2450 / 2950	0.74 / 0.88	26 / 31	4.3 / 6.0	0.17 / 0.24	26 / 30	0.37

\*All reading are typical values at rated voltage

\*Specifications are subject to change without notice

\* Bearing system B: Two Ball Bearing S: Sleeve Bearing

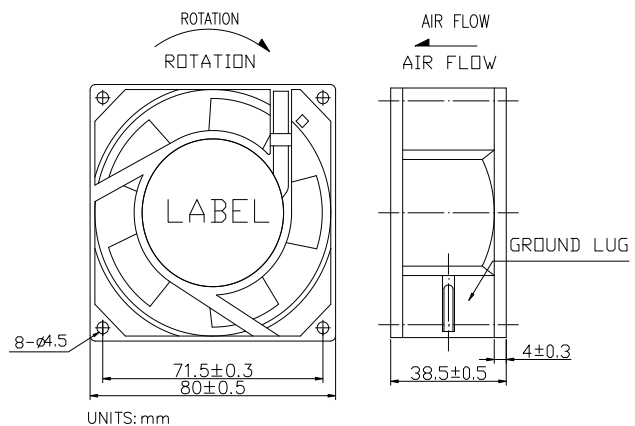
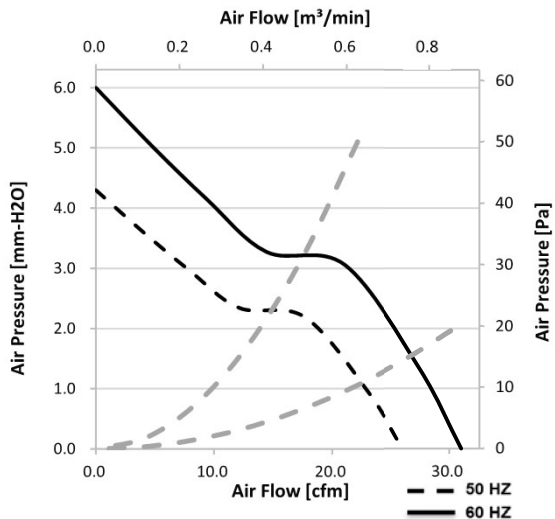

www.crownelectronics.com.tw



# 92

## IGE Series

Size (尺寸) 92\*92\*25 mm

### General Specifications (一般規格)

- ★ Motor : Shaded pole AC moto    ★ 馬達 / 交流蔽極式馬達
- ★ Frame : Aluminum                    ★ 材料 / 框 : 鋁
- ★ Impeller : Plastic (94V-0)        ★ 材料 / 葉 : 塑膠 (94V-0)
- ★ Bearing : Ball;Sleeve Bearing    ★ 軸承 / 滾珠;含油軸承
- ★ Weight : 0.29 Kg                    ★ 重量 / 0.29 公斤



### Major Characteristic Parameters

Model	Bearing System	Rated Voltage	Freq.	Input Power	Rated Speed	Maximum Air Flow		Maximum Static Pressure		Sound Level	Weight
						m3/min	CFM	mm-H2O	in-H2O		
Part NO.	B / S	V	Hz	WATT	RPM					dBA	Kg
IGE09225_1H	B S	115	50 / 60	15 / 13	2400 / 2800	0.85 / 0.99	30 / 35	4.0 / 5.0	0.16 / 0.20	30 / 31	0.29
IGE09225_2H	B S	230	50 / 60	15 / 13	2400 / 2800	0.85 / 0.99	30 / 35	4.0 / 5.0	0.16 / 0.20	30 / 31	0.29

\*All reading are typical values at rated voltage

\*Specifications are subject to change without notice

\* Bearing system B: Two Ball Bearing S: Sleeve Bearing

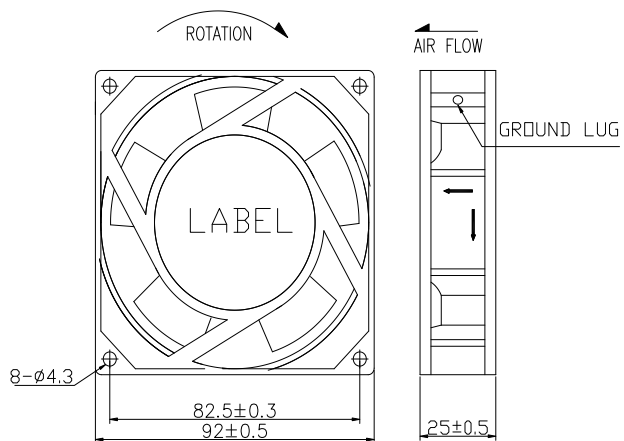
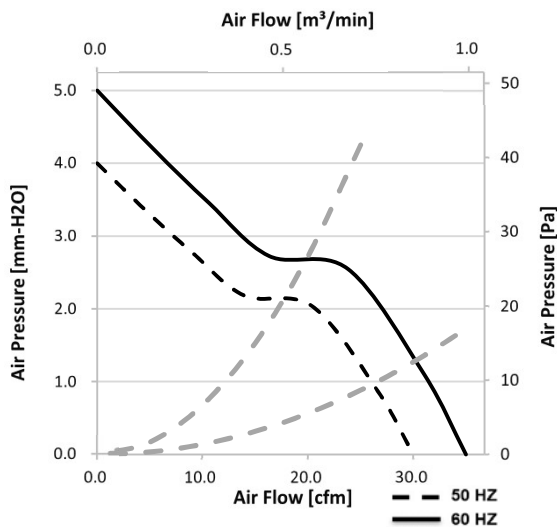

# 92

## IGE Series

Size (尺寸) 92\*92\*38 mm

### General Specifications (一般規格)

- ★ Motor : Shaded pole AC moto    ★ 馬達 / 交流蔽極式馬達
- ★ Frame : Aluminum                    ★ 材料 / 框 : 鋁
- ★ Impeller : Plastic (94V-0)        ★ 材料 / 葉 : 塑膠 (94V-0)
- ★ Bearing : Ball;Sleeve Bearing    ★ 軸承 / 滾珠;含油軸承
- ★ Weight : 0.37 Kg                    ★ 重量 / 0.37 公斤



### Major Characteristic Parameters

Model	Bearing System	Rated Voltage	Freq.	Input Power	Rated Speed	Maximum Air Flow		Maximum Static Pressure		Sound Level	Weight
Part NO.	B / S	V	Hz	WATT	RPM	m3/min	CFM	mm-H2O	in-H2O	dBA	Kg
IGE09238_1H	B S	115	50 / 60	10 / 13	2000 / 2200	1.02 / 1.13	36.0 / 40.0	3.3 / 4.3	0.13 / 0.17	36 / 38	0.37
IGE09238_2H	B S	230	50 / 60	10 / 13	2000 / 2200	1.02 / 1.13	36.0 / 40.0	3.3 / 4.3	0.13 / 0.17	36 / 38	0.37

\*All reading are typical values at rated voltage

\*Specifications are subject to change without notice

\* Bearing system B: Two Ball Bearing S: Sleeve Bearing

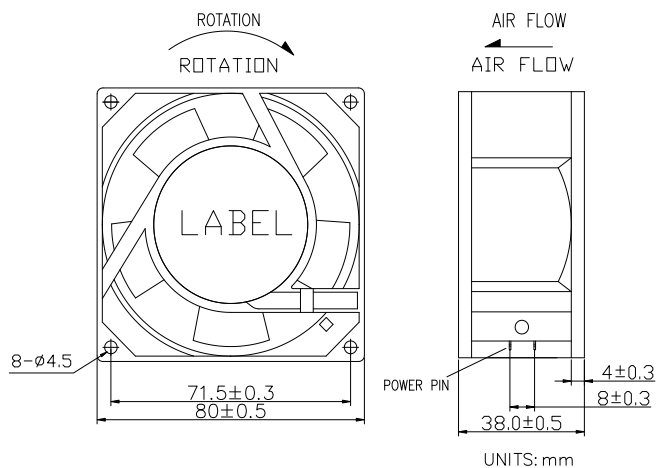
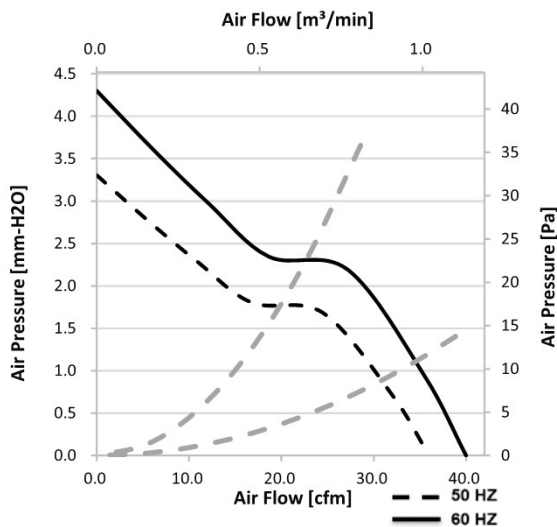

# 120 IGE Series

Size (尺寸) 120\*120\*25 mm



## General Specifications (一般規格)

- ★ Motor : Shaded pole AC moto    ★ 馬達 / 交流蔽極式馬達
- ★ Frame : Aluminum                    ★ 材料 / 框 : 鋁
- ★ Impeller : Plastic (94V-0)        ★ 材料 / 葉 : 塑膠 (94V-0)
- ★ Bearing : Ball; Sleeve Bearing   ★ 軸承 / 滾珠; 含油軸承
- ★ Weight : 0.39 Kg                    ★ 重量 / 0.39 公斤

## Major Characteristic Parameters

Model	Bearing System	Rated Voltage	Freq.	Input Power	Rated Speed	Maximum Air Flow		Maximum Static Pressure		Sound Level	Weight
						m3/min	CFM	mm-H2O	in-H2O		
Part NO.	B / S	V	Hz	WATT	RPM					dBA	Kg
IGE12025_1M	B S	115	50 / 60	14 / 13	2000 / 2200	1.65 / 2.09	58.2 / 73.6	4.1 / 4.9	0.16 / 0.19	34 / 35	0.39
IGE12025_2M	B S	230	50 / 60	14 / 13	2000 / 2200	1.65 / 2.09	58.2 / 73.6	4.1 / 4.9	0.16 / 0.19	34 / 35	0.39
IGE12025_1H	B S	110	50 / 60	20 / 17	2200 / 2500	1.81 / 2.29	64 / 81	5.0 / 5.9	0.20 / 0.23	37 / 38	0.39
IGE12025_2H	B S	230	50 / 60	20 / 17	2200 / 2500	1.81 / 2.29	64 / 81	5.0 / 5.9	0.20 / 0.23	37 / 38	0.39

\*All reading are typical values at rated voltage

\*Specifications are subject to change without notice

\* Bearing system B: Two Ball Bearing S: Sleeve Bearing

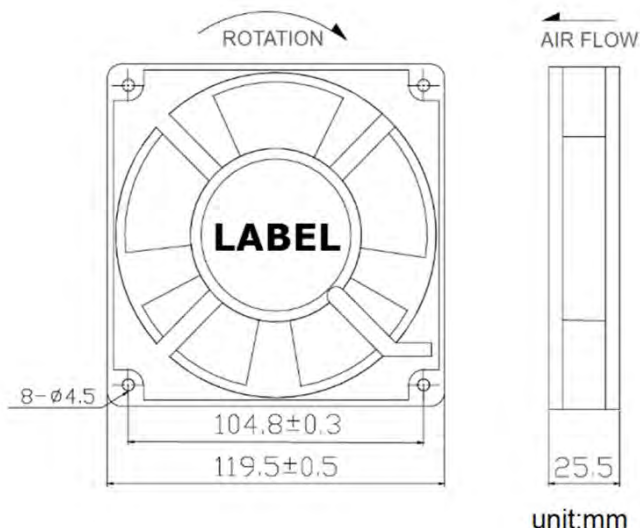
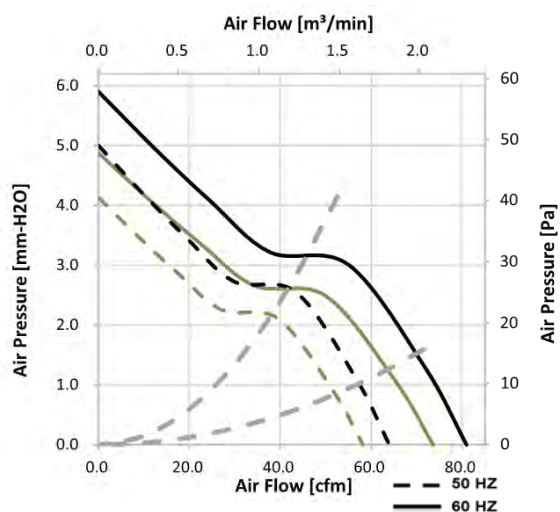

unit:mm



# 120

## IGE Series

Size (尺寸) 120\*120\*38 mm

### General Specifications (一般規格)

- ★ Motor : Shaded pole AC moto    ★ 馬達 / 交流蔽極式馬達
- ★ Frame : Aluminum                    ★ 材料 / 框 : 鋁
- ★ Impeller : Plastic (94V-0)        ★ 材料 / 葉 : 塑膠 (94V-0)
- ★ Bearing : Ball;Sleeve Bearing    ★ 軸承 / 滾珠;含油軸承
- ★ Weight : 0.53 Kg                    ★ 重量 / 0.53 公斤



### Major Characteristic Parameters

Model	Bearing System	Rated Voltage	Freq.	Input Power	Rated Speed	Maximum Air Flow		Maximum Static Pressure		Sound Level	Weight
						m3/min	CFM	mm-H2O	in-H2O		
IGE12038_1L	B S	115	50 / 60	10 / 8	2150 / 2300	2.04 / 2.21	72 / 78	2.29 / 3.30	0.09 / 0.13	26 / 27	0.53
IGE12038_2L	B S	230	50 / 60	10 / 8	2150 / 2300	2.04 / 2.21	72 / 78	2.29 / 3.30	0.09 / 0.13	26 / 27	0.53
IGE12038_1M	B S	115	50 / 60	13 / 11	2400 / 2600	2.24 / 2.41	79 / 85	3.56 / 5.33	0.14 / 0.21	36 / 37	0.53
IGE12038_2M	B S	230	50 / 60	13 / 11	2400 / 2600	2.24 / 2.41	79 / 85	3.56 / 5.33	0.14 / 0.21	36 / 37	0.53
IGE12038_1H	B S	115	50 / 60	17 / 15	2600 / 2900	2.69 / 3.11	95 / 110	6.35 / 7.62	0.25 / 0.30	43 / 44	0.53
IGE12038_2H	B S	230	50 / 60	17 / 15	2600 / 2900	2.69 / 3.11	95 / 110	6.35 / 7.62	0.25 / 0.30	43 / 44	0.53

\*All reading are typical values at rated voltage

\*Specifications are subject to change without notice

\* Bearing system B: Two Ball Bearing S: Sleeve Bearing

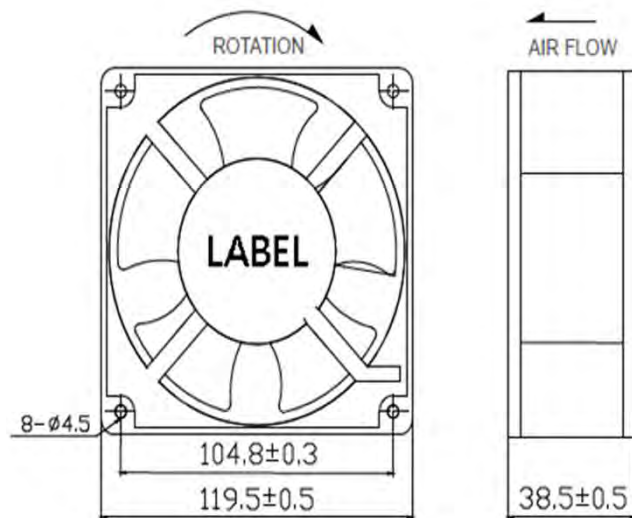
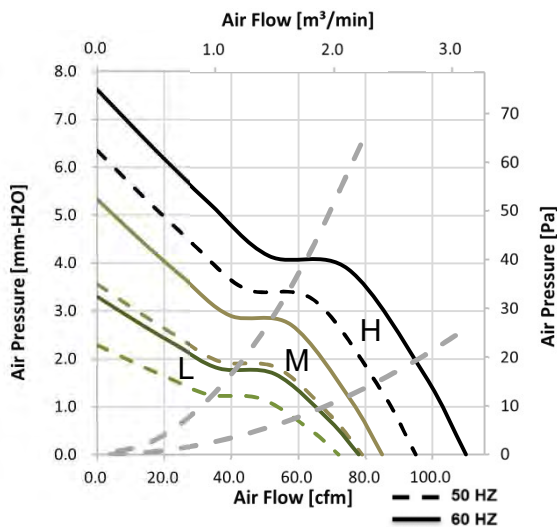

**CROWN**  
electronics

www.crownelectronics.com.tw





# 172

## IGG Series

Size (尺寸) 172x150X55 mm



### General Specifications (一般規格)

- ★ Motor : Capacitor AC motor.    ★ 馬達 / 交流電容式馬達
- ★ Frame : Aluminum                    ★ 材料 / 框 : 鋁
- ★ Impeller : Metal SPCC              ★ 材料 / 葉 : 鋼鐵
- ★ Bearing : Ball Bearing            ★ 軸承 / 滾珠軸承
- ★ Weight : 1 Kg                        ★ 重量 / 1 公斤

### Major Characteristic Parameters

Model	Bearing System	Rated Voltage	Freq.	Input Power	Rated Speed	Maximum Air Flow		Maximum Static Pressure		Sound Level	Weight
						m3/min	CFM	mm-H2O	in-H2O		
IGG17255B1H	B	115	50 / 60	46 / 44	2700 / 3000	5.38 / 6.65	190.0 / 235.0	16.0 / 17.8	0.63 / 0.70	49 / 53	1.00
IGG17255B2H	B	230	50 / 60	46 / 44	2700 / 3000	5.38 / 6.65	190.0 / 235.0	16.0 / 17.8	0.63 / 0.70	49 / 53	1.00

\*All reading are typical values at rated voltage

\*Specifications are subject to change without notice

\* Bearing system B: Two Ball Bearing S: Sleeve Bearing

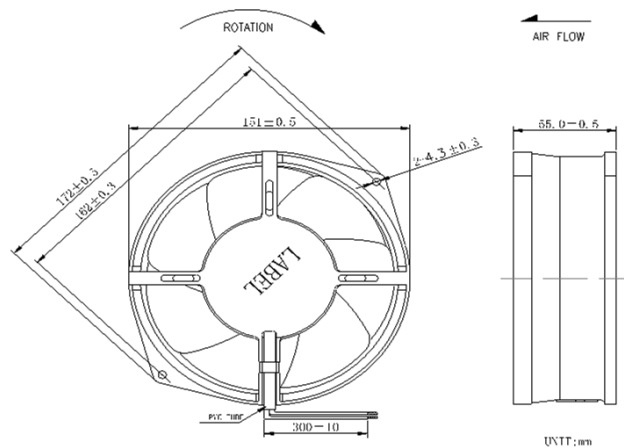
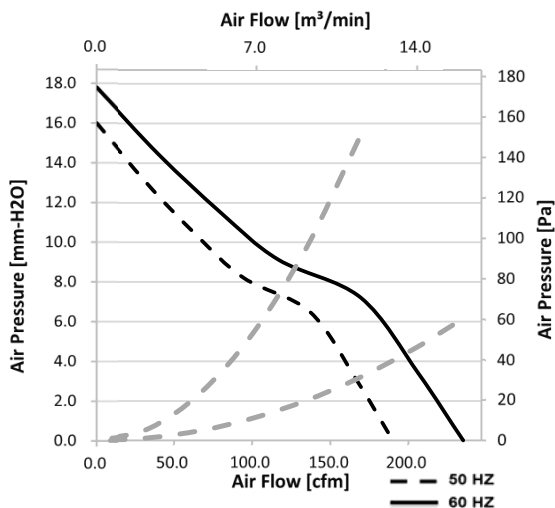

# 172

## IGE Series

Size (尺寸) 172\*150\*38 mm



### General Specifications (一般規格)

- ★ Motor : Shaded & Cap motor. ★ 馬達 / 交流蔽極式/電容式馬達
- ★ Frame : Aluminum ★ 材料 / 框 : 鋁
- ★ Impeller : Plastic (94V-0) ★ 材料 / 葉 : 塑膠 (94V-0)
- ★ Bearing : Ball Bearing ★ 軸承 / 滾珠軸承
- ★ Weight : 0.74 Kg ★ 重量 / 0.74 公斤

### Major Characteristic Parameters

Model	Bearing System	Rated Voltage	Freq.	Input Power	Rated Speed	Maximum Air Flow		Maximum Static Pressure		Sound Level	Weight
						m3/min	CFM	mm-H2O	in-H2O		
Part NO.	B / S	V	Hz	WATT	RPM					dBA	Kg
IGE17238_1M (SHADE)	B	115	50 / 60	39 / 35	2400 / 2600	4.56 / 4.81	161.0 / 170.0	9.5 / 10.0	0.37 / 0.39	50 / 51	0.74
IGE17238_2M (SHADE)	B	230	50 / 60	39 / 35	2400 / 2600	4.56 / 4.81	161.0 / 170.0	9.5 / 10.0	0.37 / 0.39	50 / 51	0.74
IGE17238_1H (CAP)	B	115	50 / 60	27 / 29	2800 / 3200	5.35 / 6.23	189 / 220	14.4 / 15.1	0.57 / 0.59	54 / 58	0.74
IGE17238_2H (CAP)	B	220	50 / 60	27 / 29	2800 / 3200	5.35 / 6.23	189 / 220.0	14.4 / 15.1	0.57 / 0.59	54 / 58	0.74

\*All reading are typical values at rated voltage

\*Specifications are subject to change without notice

\* Bearing system B: Two Ball Bearing S: Sleeve Bearing

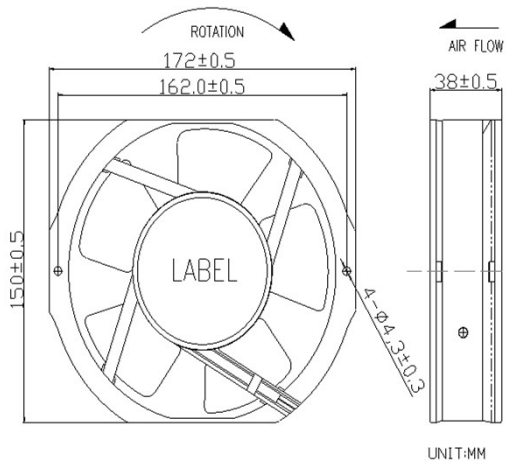
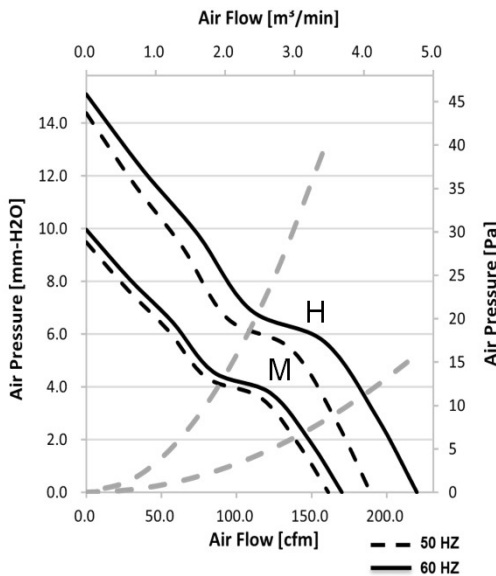

www.crownelectronics.com.tw



# 172

## IGE Series

Size (尺寸) 172\*150\*51 mm

### General Specifications (一般規格)

- ★ Motor : Shaded Pole AC moto ★ 馬達 / 交流蔽極式馬達
- ★ Frame : Aluminum ★ 材料 / 框 : 鋁
- ★ Impeller : Plastic (94V-0) ★ 材料 / 葉 : 塑膠 (94V-0)
- ★ Bearing : Ball Bearing ★ 軸承 / 滾珠軸承
- ★ Weight : 1.05 Kg ★ 重量 / 1.05 公斤



### Major Characteristic Parameters

Model	Bearing System	Rated Voltage	Freq.	Input Power	Rated Speed	Maximum Air Flow		Maximum Static Pressure		Sound Level	Weight
						m3/min	CFM	mm-H2O	in-H2O		
Part NO.	B / S	V	Hz	WATT	RPM					dBA	Kg
IGE17251_1H	B	115	50 / 60	35 / 32	2700 / 3000	5.10 / 5.66	180 / 200	9.6 / 12.2	0.38 / 0.48	50 / 52	1.05
IGE17251_2H	B	230	50 / 60	35 / 32	2700 / 3000	5.10 / 5.66	180 / 200	9.6 / 12.2	0.38 / 0.48	50 / 52	1.05

\*All reading are typical values at rated voltage

\*Specifications are subject to change without notice

\* Bearing system B: Two Ball Bearing S: Sleeve Bearing

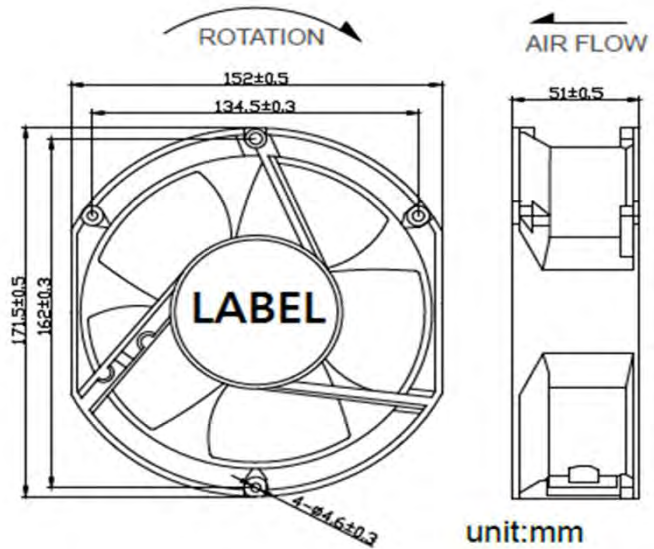
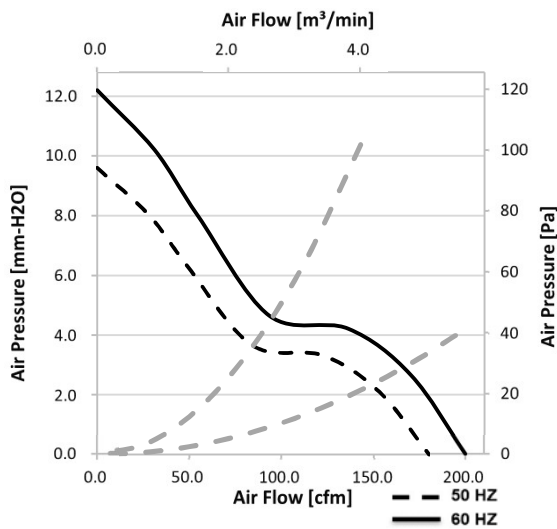

www.crownelectronics.com.tw



# 200

## IGF Series

Size (尺寸) 200\*200\*60 mm

### General Specifications (一般規格)

- ★ Motor : Capacitor AC motor.    ★ 馬達 / 交流電容式馬達
- ★ Frame : Aluminum                    ★ 材料 / 框 : 鋁
- ★ Impeller : Plastic (94V-0)        ★ 材料 / 葉 : 塑膠 (94V-0)
- ★ Bearing : Ball Bearing            ★ 軸承 / 滾珠軸承
- ★ Weight : 1.7 Kg                    ★ 重量 / 1.7 公斤



### Major Characteristic Parameters

Model	Bearing System	Rated Voltage	Freq.	Input Power	Rated Speed	Maximum Air Flow		Maximum Static Pressure		Sound Level	Weight
						m3/min	CFM	mm-H2O	in-H2O		
IGF20060_1H	B	115	50 / 60	68 / 75	2550 / 2050	12.74 / 14.72	471.0 / 565.0	12.5 / 15.1	0.26 / 0.31	68 / 62	1.70
IGF20060_2H	B	230	50 / 60	62 / 70	2550 / 2050	12.74 / 14.72	471.0 / 565.0	12.5 / 15.1	0.26 / 0.31	68 / 62	1.70

\*All reading are typical values at rated voltage

\*Specifications are subject to change without notice

\* Bearing system B: Two Ball Bearing S: Sleeve Bearing

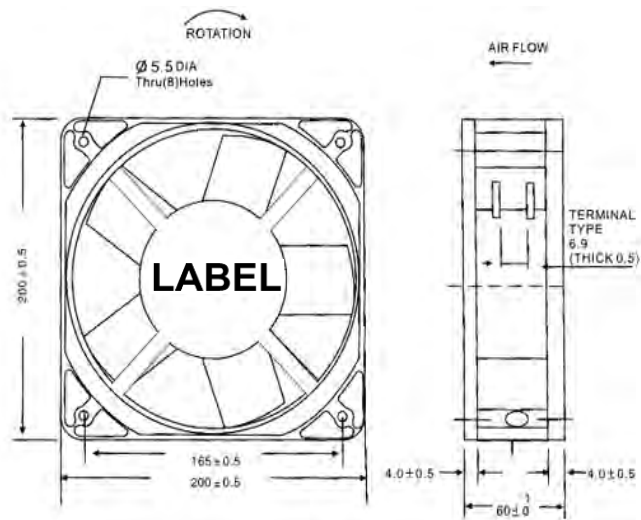
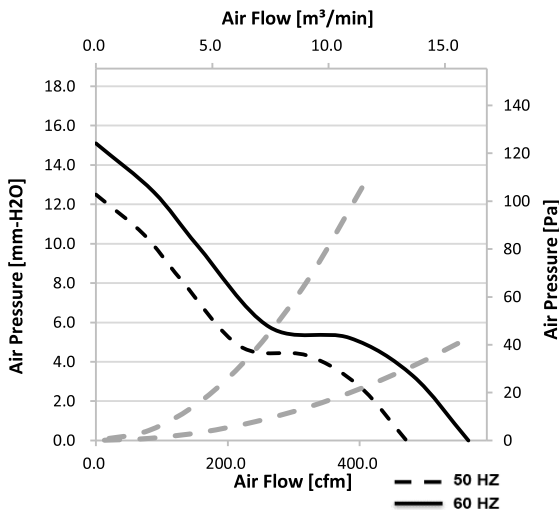

# 225 IGG Series

## Size (尺寸) 225\*225\*80



### General Specifications (一般規格)

- ★ Motor : Shaded Pole motor.      ★ 馬達 / 交流蔽極式馬達
- ★ Frame : Aluminum                      ★ 材料 / 框 : 鋁
- ★ Impeller : Metal SPCC                ★ 材料 / 葉 : 鋼鐵
- ★ Bearing : Ball Bearing                ★ 軸承 / 滾珠軸承
- ★ Weight : 2.11 Kg                        ★ 重量 / 2.11 公斤
- ★ IPXX Rank : IP43                        ★ 防水等級 : IP43

### Major Characteristic Parameters

Model	Bearing System	Rated Voltage	Freq.	Input Power	Rated Speed	Maximum Air Flow		Maximum Static Pressure		Sound Level	Weight
						m3/min	CFM	mm-H2O	in-H2O		
IGG22580B2H	B	230	50 / 60	60 / 78	2550 / 2750	15.4 / 17.2	545 / 607	15.8 / 18.4	0.62 / 0.72	60 / 62	2.11
IGG22580B1H	B	115	50 / 60	60 / 78	2550 / 2750	15.4 / 17.2	545 / 607	15.8 / 18.4	0.62 / 0.72	60 / 62	2.11
IGG22580B3H	B	380	50 / 60	60 / 78	2550 / 2750	15.4 / 17.2	545 / 607	15.8 / 18.4	0.62 / 0.72	60 / 62	2.11

\*All reading are typical values at rated voltage

\*Specifications are subject to change without notice

\* Bearing system B: Two Ball Bearing S: Sleeve Bearing

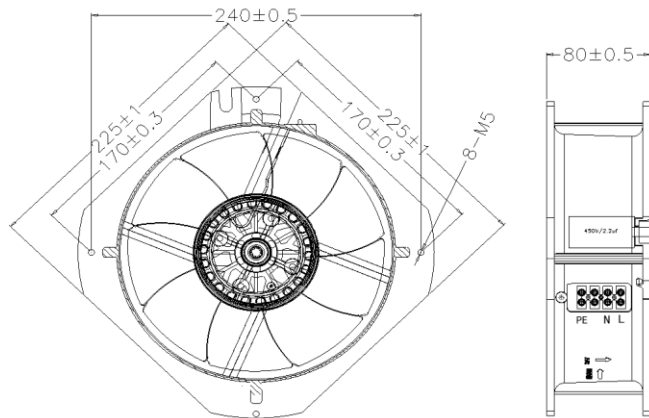
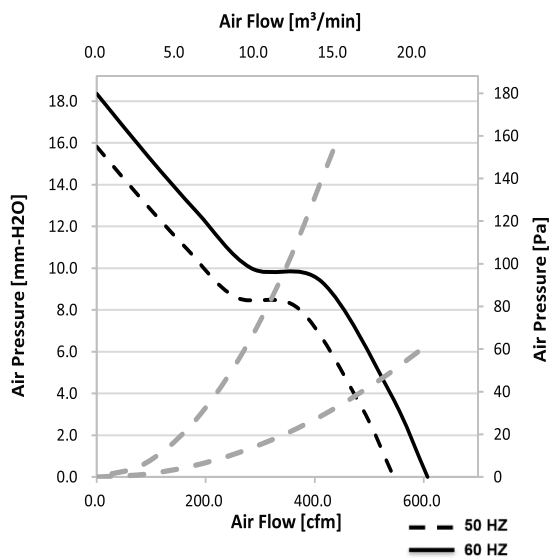

# 254

## IGE Series

Size (尺寸) Ø254\*89 mm

### General Specifications (一般規格)

- ★ Motor : Capacitor AC motor.    ★ 馬達 / 交流電容式馬達
- ★ Frame : Aluminum                    ★ 材料 / 框 : 鋁
- ★ Impeller : Plastic (94V-0)        ★ 材料 / 葉 : 塑膠 (94V-0)
- ★ Bearing : Ball Bearing            ★ 軸承 / 滾珠軸承
- ★ Weight : 2 Kg                        ★ 重量 / 2 公斤



### Major Characteristic Parameters

Model	Bearing System	Rated Voltage	Freq.	Input Power	Rated Speed	Maximum Air Flow		Maximum Static Pressure		Sound Level	Weight
						m3/min	CFM	mm-H2O	in-H2O		
IGE25489_1M	B	115	50 / 60	34 / 37	1400 / 1600	12.74 / 14.72	450 / 520	6.6 / 7.9	0.26 / 0.31	49 / 51	2.00
IGE25489_2M	B	230	50 / 60	34 / 37	1400 / 1600	12.74 / 14.72	450 / 520	6.6 / 7.9	0.26 / 0.31	49 / 51	2.00
IGE25489_1H	B	115	50 / 60	60 / 67	2000 / 2150	17.84 / 19.82	630 / 700	7.9 / 8.7	0.31 / 0.34	54 / 56	2.00
IGE25489_2H	B	230	50 / 60	60 / 67	2000 / 2150	17.84 / 19.82	630 / 700	7.9 / 8.7	0.31 / 0.34	54 / 56	2.00

\*All reading are typical values at rated voltage

\*Specifications are subject to change without notice

\* Bearing system B: Two Ball Bearing S: Sleeve Bearing

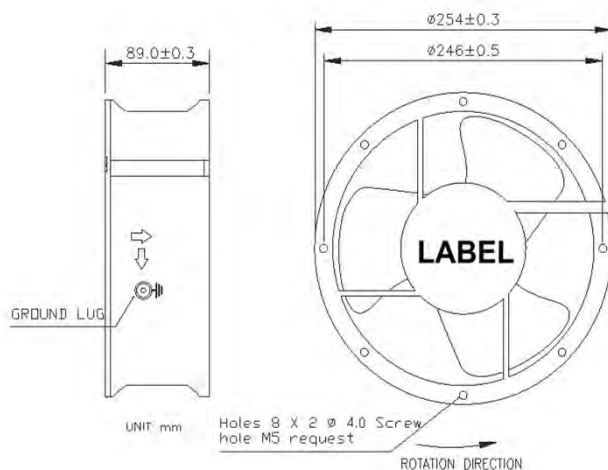
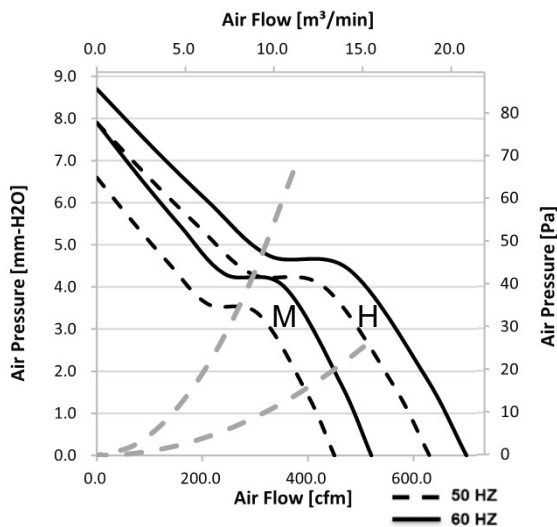

www.crownelectronics.com.tw



# 254 IGH Series

## Size (尺寸) Ø254\*89 mm



### General Specifications (一般規格)

- ★ Motor : Capacitor AC motor.   ★ 馬達 / 交流電容式馬達
- ★ Frame : Aluminum                   ★ 材料 / 框 : 鋁
- ★ Impeller : Plastic (94V-0)       ★ 材料 / 葉 : 塑膠 (94V-0)
- ★ Bearing : Ball Bearing           ★ 軸承 / 滾珠軸承
- ★ Weight : 2 Kg                      ★ 重量 / 2 公斤

### Major Characteristic Parameters

Model	Bearing System	Rated Voltage	Freq.	Input Power	Rated Speed	Maximum Air Flow		Maximum Static Pressure		Sound Level	Weight
						m3/min	CFM	mm-H2O	in-H2O		
Part NO.	B / S	V	Hz	WATT	RPM					dBA	Kg
IGH25489_1H	B	115	50 / 60	95 / 125	2600 / 2750	23.22 / 25.77	820.0 / 910.0	23.0 / 25.2	0.91 / 0.99	64 / 66	2.0
IGH25489_2H	B	230	50 / 60	95 / 125	2600 / 2750	23.22 / 25.77	820.0 / 910.0	23.0 / 25.2	0.91 / 0.99	64 / 66	2.0

\*All reading are typical values at rated voltage

\*Specifications are subject to change without notice

\* Bearing system B: Two Ball Bearing S: Sleeve Bearing

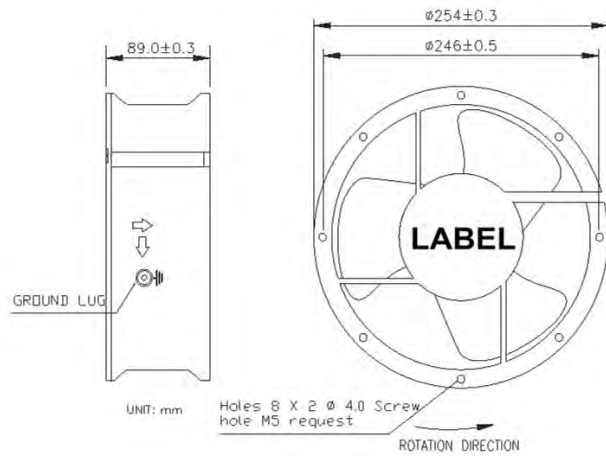
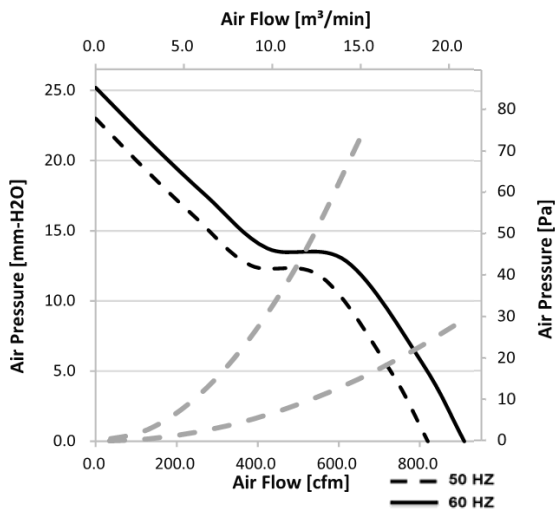

# 280 IGG Series

## Size (尺寸) 280\*280\*80



### General Specifications (一般規格)

- ★ Motor : Shaded Pole motor.      ★ 馬達 / 交流蔽極式馬達
- ★ Frame : Aluminum                      ★ 材料 / 框 : 鋁
- ★ Impeller : Metal SPCC                ★ 材料 / 葉 : 鋼鐵
- ★ Bearing : Ball Bearing                ★ 軸承 / 滾珠軸承
- ★ Weight : 2.8 Kg                        ★ 重量 / 2.8 公斤
- ★ IPXX Rank : IP43                       ★ 防水等級 : IP43

### Major Characteristic Parameters

Model	Bearing System	Rated Voltage	Freq.	Input Power	Rated Speed	Maximum Air Flow		Maximum Static Pressure		Sound Level	Weight
						m3/min	CFM	mm-H2O	in-H2O		
IGG28080B2H	B	230	50 / 60	120 / 150	2550 / 2800	31.1 / 32.8	1098 / 1160	19.2 / 23.1	0.76 / 0.91	70 / 72	2.80
IGG28080B1H	B	115	50 / 60	120 / 150	2550 / 2800	31.1 / 32.8	1098 / 1160	19.2 / 23.1	0.76 / 0.91	70 / 72	2.80

\*All reading are typical values at rated voltage

\*Specifications are subject to change without notice

\* Bearing system B: Two Ball Bearing S: Sleeve Bearing

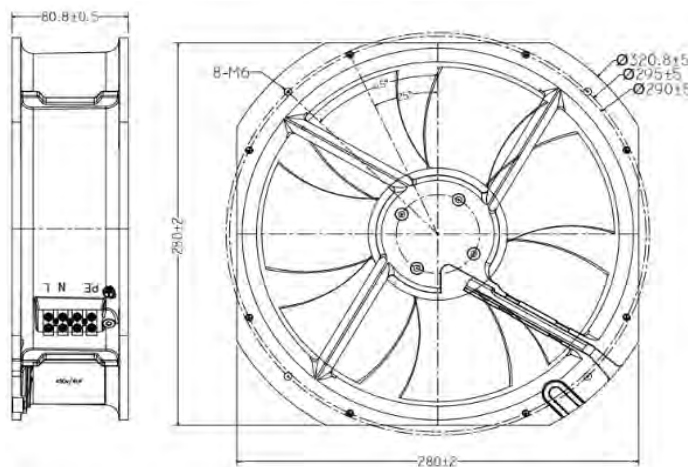
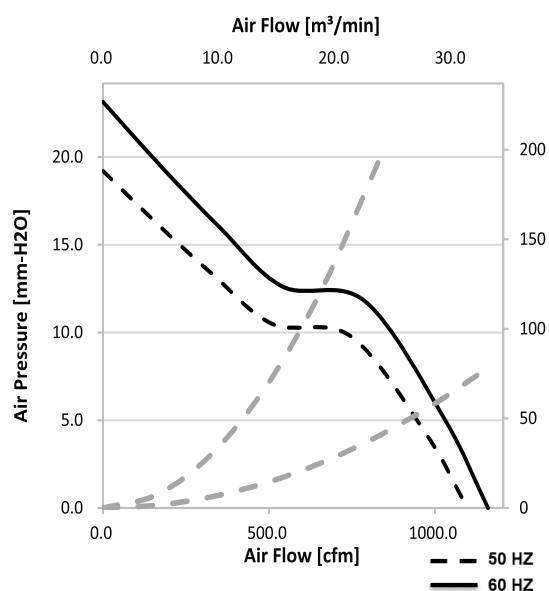



# Finger Guards

Dimensions(Unit:mm)

## □ 25mm type

Model:CS025-2  
Surface treatment:Nickel-chrome plating  
Color:silver

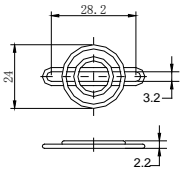

## □ 35mm type

Model:CS035-2  
Surface treatment:Nickel-chrome plating  
Color:silver

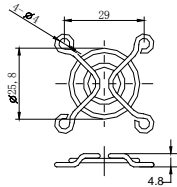

## □ 40mm type

Model:CS040-2  
Surface treatment:Nickel-chrome plating  
Color:silver

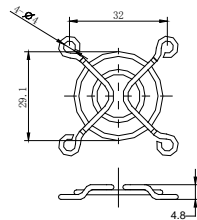

## □ 50mm type

Model:CS050-3  
Surface treatment:Nickel-chrome plating  
Color:silver

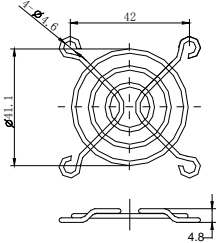

## □ 60mm type

Model:CS060-5  
Surface treatment:Nickel-chrome plating  
Color:silver

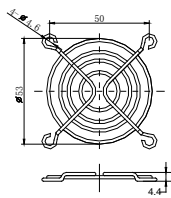

## □ 70mm type

Model:CS070-5  
Surface treatment:Nickel-chrome plating  
Color:silver

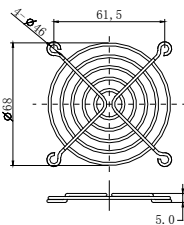

## □ 80mm type

Model:CS080-5  
Surface treatment:Nickel-chrome plating  
Color:silver

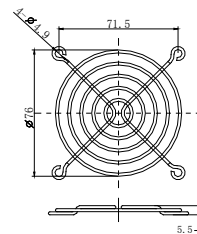

## □ 92mm type

Model:CS092-6  
Surface treatment:Nickel-chrome plating  
Color:silver

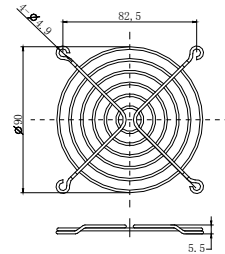

## ∅120mm type

Model:CS120-8  
Surface treatment:Nickel-chrome plating  
Color:silver

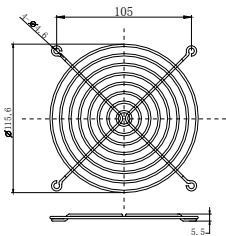

## ∅150mm type

Model:CS150-8  
Surface treatment:Nickel-chrome plating  
Color:silver

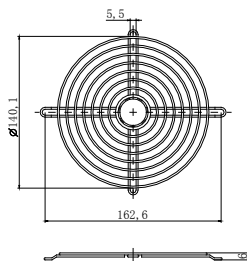

## ∅150mm type

Model:CS150-10  
Surface treatment:Nickel-chrome plating  
Color:silver

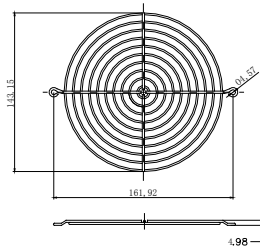

## ∅250mm type

Model:CS250-10  
Surface treatment:Nickel-chrome plating  
Color:silver

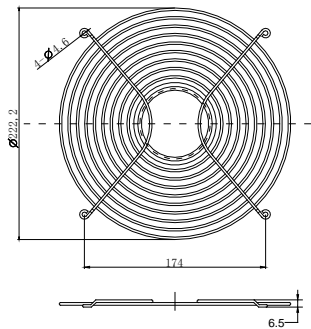

# Resin Finger Guards

Dimensions(Unit:mm)

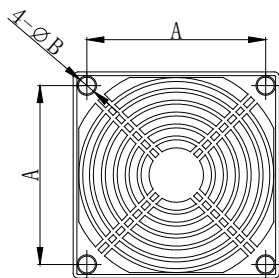

Material:ABS

Unit:mm

P/N	Fan Size	Dimension	
		A	B
CRF01	40x40mm	43.0	3.0
CRF02	60x60mm	64.5	5.0
CRF03	80x80mm	86.0	4.8
CRF04	92x92mm	96.2	4.8
CRF05	120x120mm	125.5	5.7

Material:ABS

Fan size:Ø150X51,Ø172X51

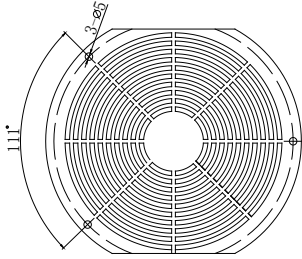

Material:ABS

Fan size:Ø254X89

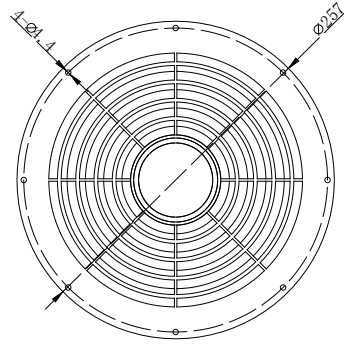

## Resin filter kits

Hood

Filter

Main body

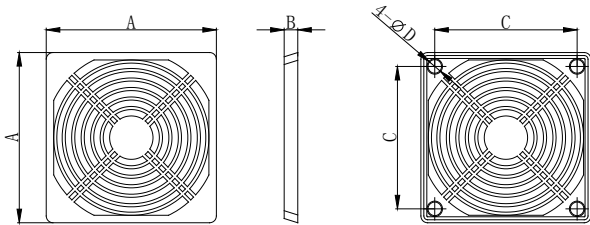

Material:ABS

Structure:Hood, Filter, Main body

Unit:mm

P/N	Fan Size	Dimension			
		A	B	C	D
CRF01	40x40mm	43.0	6.2	32.0	3.0
CRF02	60x60mm	64.5	7.0	50.5	5.0
CRF03	80x80mm	86.0	10.0	71.0	4.8
CRF04	92x92mm	96.2	10.0	83.0	4.8
CRF05	120x120mm	125.5	10.0	105.0	5.7

## Ventilator filter kits

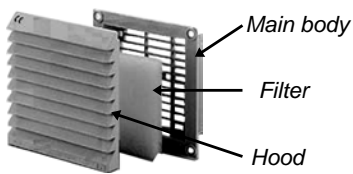

Material:ABS(UL 94V-0)

Structure:Hood, Filter, Main body

Water proof:IP44

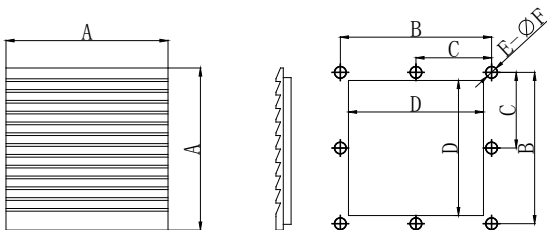

P/N	Fan Size	Dimension					
		A	B	C	D	E	F
CFU-120	120x120mm	148.5	131.0	65.5	122.0	8	5.0
CFU-150	150x150mm	204.0	184.0	92.0	175.0	8	5.0
CFU-250	250x250mm	255.0	233.0	116.5	223.0	8	5.0

Unit:mm

# Plug Cord

## 180° type

Model:CP01-1  
Rohs compliance

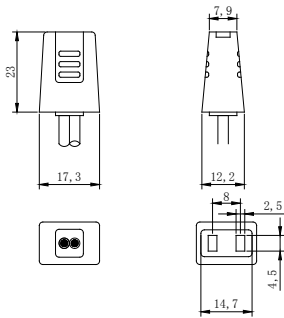

## 90° type

Model:CP01-2  
Rohs compliance

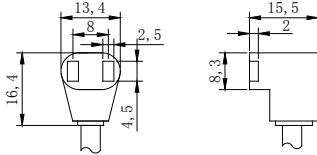

## 45° type

Model:CP01-3  
Rohs compliance

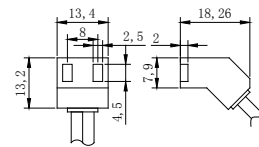

# Rubber Fan Mount

## General Specification

Model:Ruber  
Application: 40X40mm to 120mmX120mm DC axial fans  
Rohs compliance

### A type

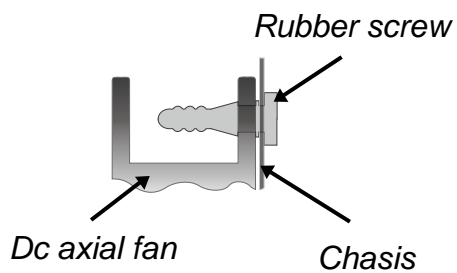

### B type

