

CROWN
electronics

CROWN EXTERNAL ROTOR FAN CATALOG

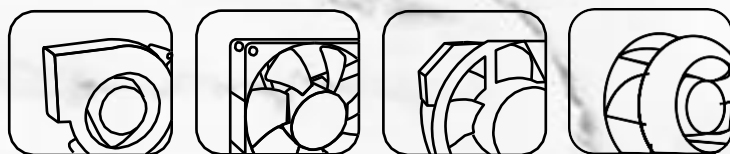

CROWN ELECTRONICS CO., LTD



WWW.CROWNELECTRONICS.COM.TW

200 JGT Series

Size (尺寸) Φ 200 mm

General Specifications (一般規格)

- ★ Motor : Capacitor motor. ★ 馬達 : 交流電容式馬達
- ★ Guard : Steel ★ 材料 / 框 : 鋼網
- ★ Impeller : Metal SPCC ★ 材料 / 葉 : 鋼鐵
- ★ Bearing : Ball Bearing ★ 軸承 / 滾珠軸承
- ★ IPXX Rank : IP54 ★ 防水等級 : IP54



AC External Rotor (交流外轉子風機)

Major Characteristic Parameters

Model	Bearing System	Rated Voltage	Freq.	Input Power	Rated Speed	Maximum Air Flow		Weight
Part NO.	B / S	VAC	Hz	WATT	RPM	m3/min	CFM	Kg
JGT200B2H	B	220~240	50 / 60	68 / 80	2500 / 2700	17.5 / 21.5	618 / 760	2.3
JGT200B4H	B	380~420	50 / 60	68 / 80	2500 / 2700	17.5 / 21.5	618 / 760	2.3

*All reading are typical values at rated voltage

*Specifications are subject to change without notice

* Bearing system B: Two Ball Bearing

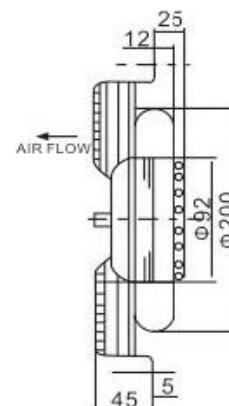
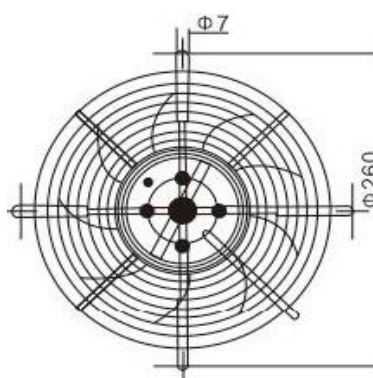
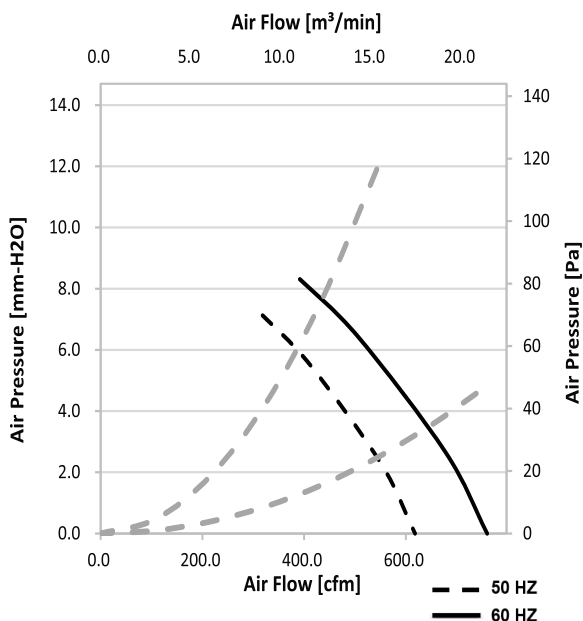

www.crownelectronics.com.tw



250 JGT Series

Size (尺寸) Φ 250 mm

General Specifications (一般規格)

- ★ Motor : Capacitor motor. ★ 馬達 : 交流電容式馬達
- ★ Guard : Steel ★ 材料 / 框 : 鋼網
- ★ Impeller : Metal SPCC ★ 材料 / 葉 : 鋼鐵
- ★ Bearing : Ball Bearing ★ 軸承 / 滾珠軸承
- ★ IPXX Rank : IP54 ★ 防水等級 : IP54



AC External Rotor (交流外轉子風機)

Major Characteristic Parameters

Model	Bearing System	Rated Voltage	Freq.	Input Power	Rated Speed	Maximum Air Flow		Weight
						m3/min	CFM	
Part NO.	B / S	VAC	Hz	WATT	RPM			Kg
JGT250B2H	B	220 ~ 240	50 / 60	102 / 120	2500 / 2700	14.0 / 16.0	494 / 565	2.8
JGT250B4H	B	380 ~ 420	50 / 60	102 / 120	2500 / 2700	14.0 / 16.0	494 / 565	2.8

*All reading are typical values at rated voltage

*Specifications are subject to change without notice

* Bearing system B: Two Ball Bearing

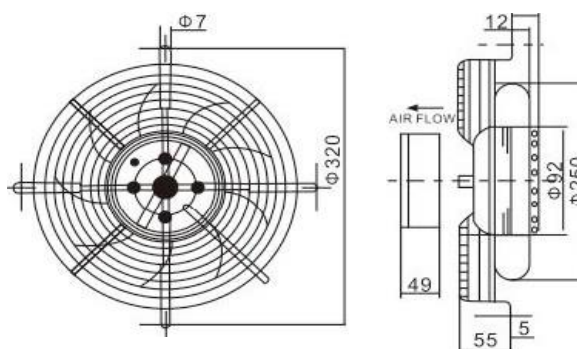
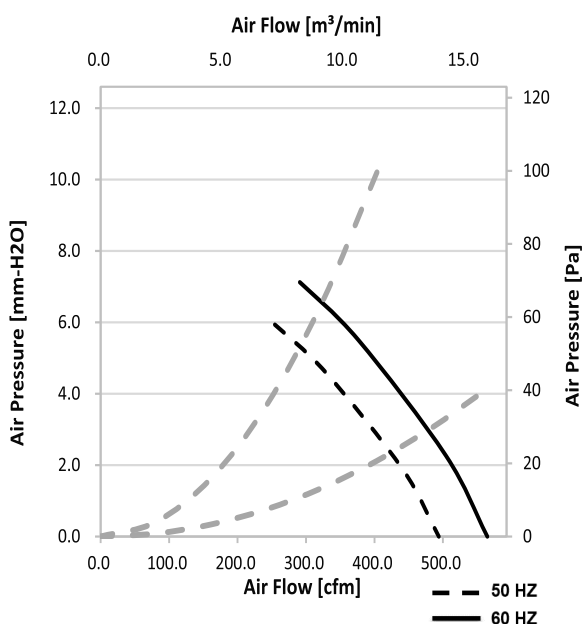

www.crownelectronics.com.tw



300

JGT Series

Size (尺寸) Φ 300 mm

General Specifications (一般規格)

- ★ Motor : Capacitor motor. ★ 馬達 : 交流電容式馬達
- ★ Guard : Steel ★ 材料 / 框 : 鋼網
- ★ Impeller : Metal SPCC ★ 材料 / 葉 : 鋼鐵
- ★ Bearing : Ball Bearing ★ 軸承 / 滾珠軸承
- ★ IPXX Rank : IP54 ★ 防水等級 : IP54

AC External Rotor (交流外轉子風機)



Major Characteristic Parameters

Model	Bearing System	Rated Voltage	Freq.	Input Power	Rated Speed	Maximum Air Flow		Weight
Part NO.	B / S	VAC	Hz	WATT	RPM	m3/min	CFM	Kg
JGT300B2H	B	220 ~ 240	50 / 60	124 / 145	2500 / 2700	29.6 / 32.0	1047 / 1130	5
JGT300B4H	B	380 ~ 420	50 / 60	124 / 145	2500 / 2700	29.6 / 32.0	1047 / 1130	5

*All reading are typical values at rated voltage

*Specifications are subject to change without notice

* Bearing system B: Two Ball Bearing

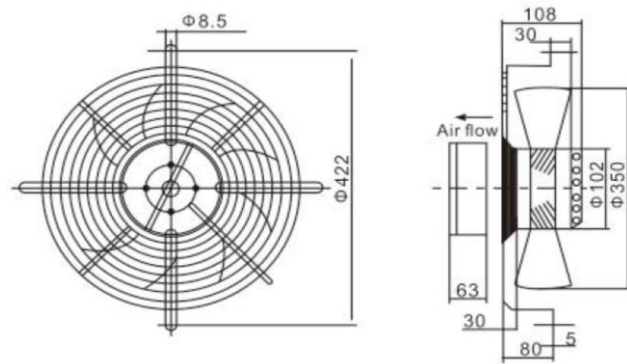
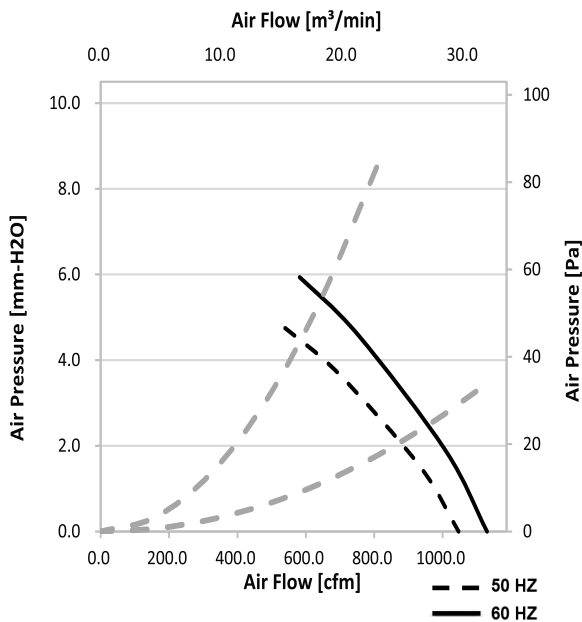

www.crownelectronics.com.tw



400

JGT Series

Size (尺寸) Φ 400 mm

General Specifications (一般規格)

- ★ Motor : Capacitor motor. ★ 馬達 : 交流電容式馬達
- ★ Guard : Steel ★ 材料 / 框 : 鋼網
- ★ Impeller : Metal SPCC ★ 材料 / 葉 : 鋼鐵
- ★ Bearing : Ball Bearing ★ 軸承 / 滾珠軸承
- ★ IPXX Rank : IP54 ★ 防水等級 : IP54



AC External Rotor (交流外轉子風機)

Major Characteristic Parameters

Model	Bearing System	Rated Voltage	Freq.	Input Power	Rated Speed	Maximum Air Flow		Weight
Part NO.	B / S	VAC	Hz	WATT	RPM	m3/min	CFM	Kg
JGT400B2H	B	220 ~ 240	50 / 60	167 / 195	2500 / 2700	68.0 / 73.3	2400 / 2589	7
JGT400B4H	B	380 ~ 420	50 / 60	167 / 195	2500 / 2700	68.0 / 73.3	2400 / 2589	7

*All reading are typical values at rated voltage

*Specifications are subject to change without notice

* Bearing system B: Two Ball Bearing

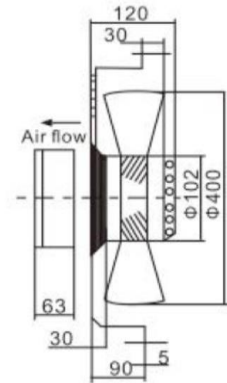
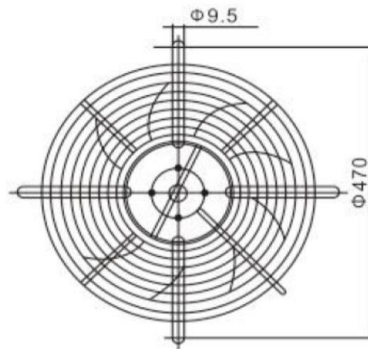
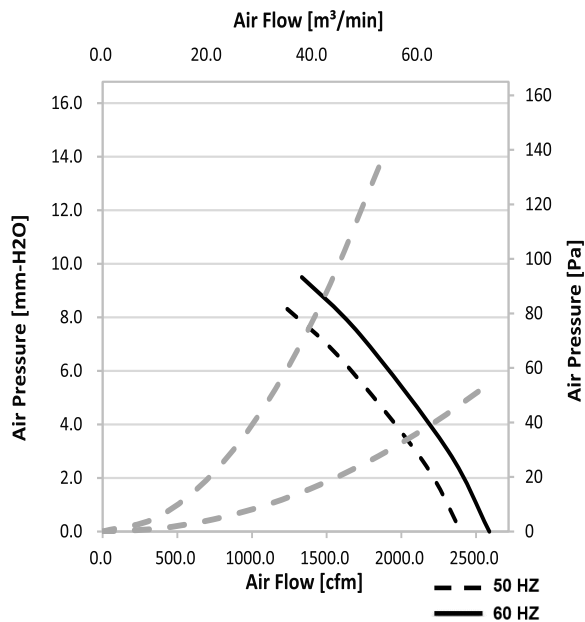

www.crownelectronics.com.tw



450

JGT Series

Size (尺寸) Φ 450 mm

General Specifications (一般規格)

- ★ Motor : Capacitor motor. ★ 馬達 : 交流電容式馬達
- ★ Guard : Steel ★ 材料 / 框 : 鋼網
- ★ Impeller : Metal SPCC ★ 材料 / 葉 : 鋼鐵
- ★ Bearing : Ball Bearing ★ 軸承 / 滾珠軸承
- ★ IPXX Rank : IP54 ★ 防水等級 : IP54



AC External Rotor (交流外轉子風機)

Major Characteristic Parameters

Model	Bearing System	Rated Voltage	Freq.	Input Power	Rated Speed	Maximum Air Flow		Weight
						m3/min	CFM	
Part NO.	B / S	VAC	Hz	WATT	RPM			Kg
JGT450B2H	B	220 ~ 240	50 / 60	187 / 250	1300 / 1500	84.9 / 90.3	3000 / 3189	8
JGT450B4H	B	380 ~ 420	50 / 60	187 / 250	1300 / 1500	84.9 / 90.3	3000 / 3189	8

*All reading are typical values at rated voltage

*Specifications are subject to change without notice

* Bearing system B: Two Ball Bearing

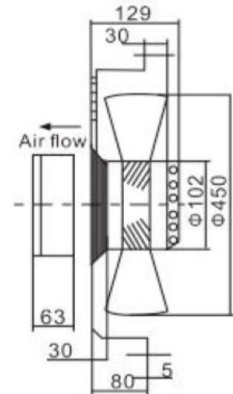
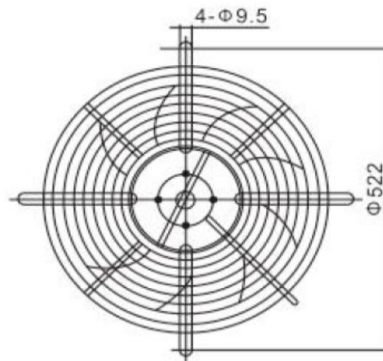
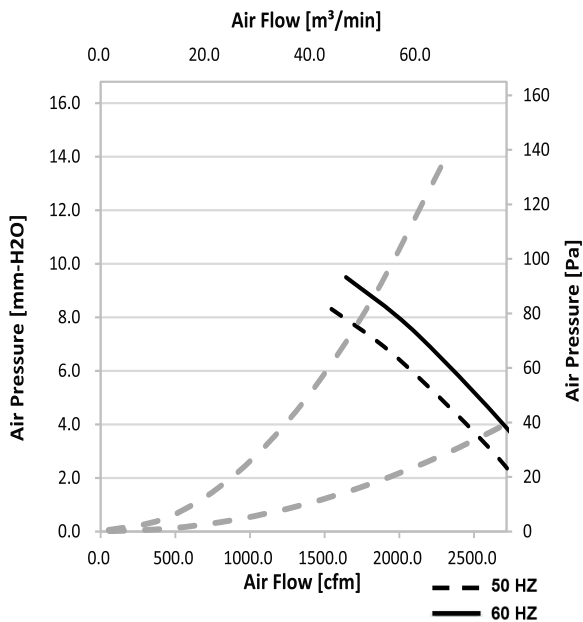

www.crownelectronics.com.tw



500

JGT Series

Size (尺寸) Φ 500 mm



General Specifications (一般規格)

- ★ Motor : Capacitor motor. ★ 馬達 : 交流電容式馬達
- ★ Guard : Steel ★ 材料 / 框 : 鋼網
- ★ Impeller : Metal SPCC ★ 材料 / 葉 : 鋼鐵
- ★ Bearing : Ball Bearing ★ 軸承 / 滾珠軸承
- ★ IPXX Rank : IP54 ★ 防水等級 : IP54

AC External Rotor (交流外轉子風機)

Major Characteristic Parameters

Model	Bearing System	Rated Voltage	Freq.	Input Power	Rated Speed	Maximum Air Flow		Weight
						m3/min	CFM	
Part NO.	B / S	VAC	Hz	WATT	RPM			Kg
JGT500B2H	B	220~240	50 / 60	375 / 500	1300 / 1500	101.9 / 107.3	3600 / 3789	10
JGT500B4H	B	380~420	50 / 60	375 / 500	1300 / 1500	101.9 / 107.3	3600 / 3789	10

*All reading are typical values at rated voltage

*Specifications are subject to change without notice

* Bearing system B: Two Ball Bearing

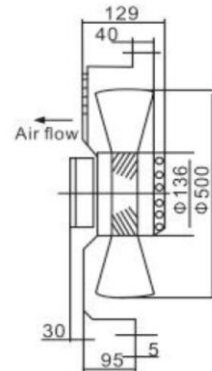
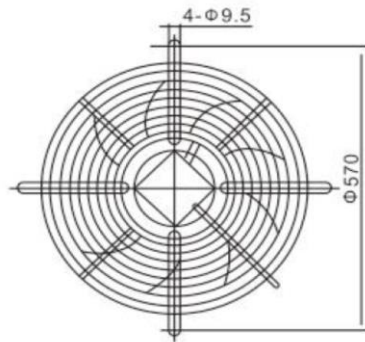
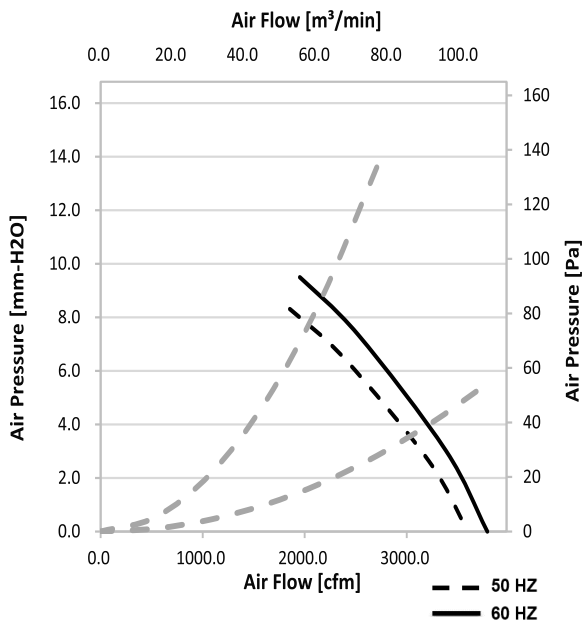

www.crownelectronics.com.tw



550

JGT Series

Size (尺寸) Φ 550 mm

General Specifications (一般規格)

- ★ Motor : Capacitor motor. ★ 馬達 : 交流電容式馬達
- ★ Guard : Steel ★ 材料 / 框 : 鋼網
- ★ Impeller : Metal SPCC ★ 材料 / 葉 : 鋼鐵
- ★ Bearing : Ball Bearing ★ 軸承 / 滾珠軸承
- ★ IPXX Rank : IP54 ★ 防水等級 : IP54

AC External Rotor (交流外轉子風機)



Major Characteristic Parameters

Model	Bearing System	Rated Voltage	Freq.	Input Power	Rated Speed	Maximum Air Flow		Weight
						m3/min	CFM	
Part NO.	B / S	VAC	Hz	WATT	RPM			Kg
JGT550B2H	B	220~240	50 / 60	413 / 550	1300 / 1500	118.9 / 124.3	4200 / 4389	12
JGT550B4H	B	380~420	50 / 60	413 / 550	1300 / 1500	118.9 / 124.3	4200 / 4389	12

*All reading are typical values at rated voltage

*Specifications are subject to change without notice

* Bearing system B: Two Ball Bearing

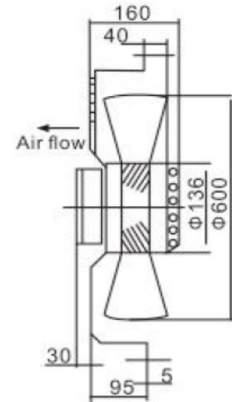
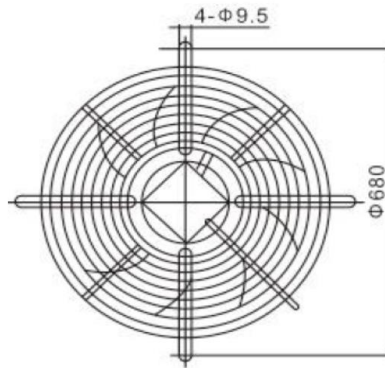
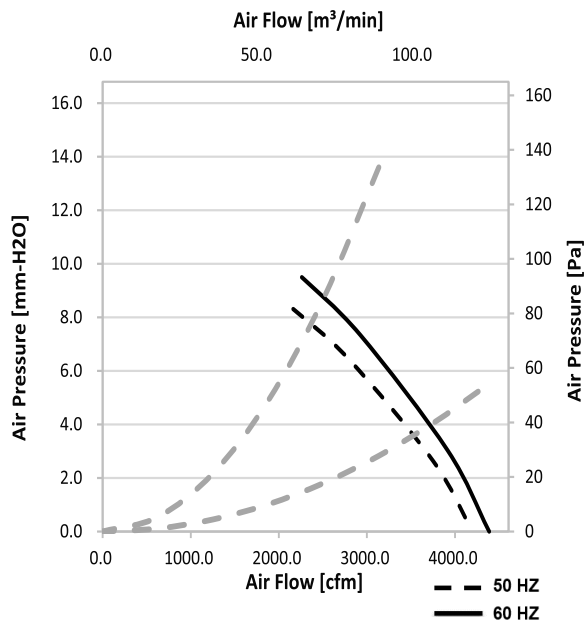

www.crownelectronics.com.tw



600 JGT Series

Size (尺寸) Φ 600 mm



General Specifications (一般規格)

- ★ Motor : Capacitor motor. ★ 馬達 : 交流電容式馬達
- ★ Guard : Steel ★ 材料 / 框 : 鋼網
- ★ Impeller : Metal SPCC ★ 材料 / 葉 : 鋼鐵
- ★ Bearing : Ball Bearing ★ 軸承 / 滾珠軸承
- ★ IPXX Rank : IP54 ★ 防水等級 : IP54

AC External Rotor (交流外轉子風機)

Major Characteristic Parameters

Model	Bearing System	Rated Voltage	Freq.	Input Power	Rated Speed	Maximum Air Flow		Weight
						m3/min	CFM	
Part NO.	B / S	VAC	Hz	WATT	RPM			Kg
JGT600B2H	B	220 ~ 240	50 / 60	520 / 780	1300 / 1500	135.9 / 141.3	4800 / 4989	14
JGT600B4H	B	380 ~ 420	50 / 60	520 / 780	1300 / 1500	135.9 / 141.3	4800 / 4989	14

*All reading are typical values at rated voltage

*Specifications are subject to change without notice

* Bearing system B: Two Ball Bearing

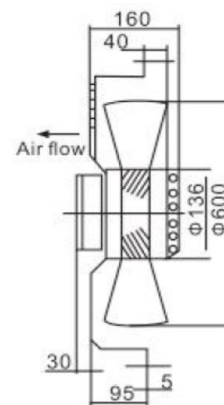
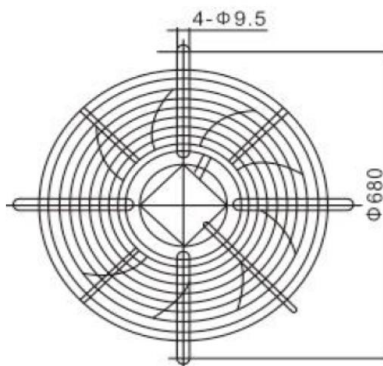
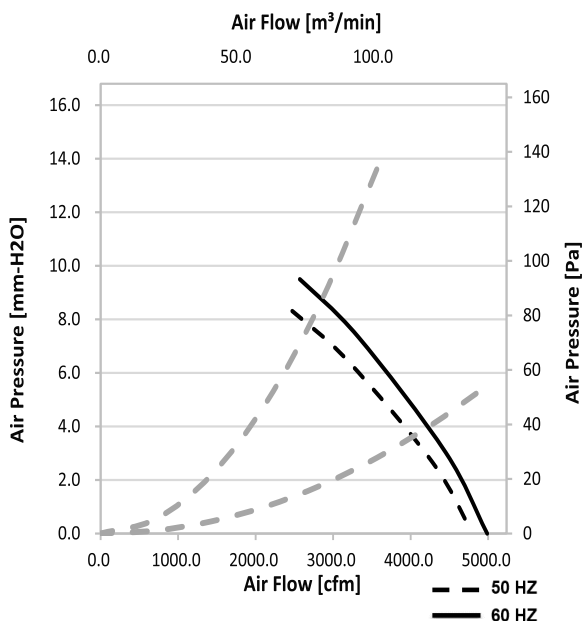

www.crownelectronics.com.tw



630

JGT Series

Size (尺寸) Φ 630 mm

General Specifications (一般規格)

- ★ Motor : Capacitor motor. ★ 馬達 : 交流電容式馬達
- ★ Guard : Steel ★ 材料 / 框 : 鋼網
- ★ Impeller : Metal SPCC ★ 材料 / 葉 : 鋼鐵
- ★ Bearing : Ball Bearing ★ 軸承 / 滾珠軸承
- ★ IPXX Rank : IP54 ★ 防水等級 : IP54

AC External Rotor (交流外轉子風機)



Major Characteristic Parameters

Model	Bearing System	Rated Voltage	Freq.	Input Power	Rated Speed	Maximum Air Flow		Weight
						m3/min	CFM	
Part NO.	B / S	VAC	Hz	WATT	RPM			Kg
JGT630B2H	B	220~240	50 / 60	732 / 850	1300 / 1400	311.5 / 382.3	11000 / 13500	15
JGT630B4H	B	380~420	50 / 60	732 / 850	1300 / 1400	311.5 / 382.3	11000 / 13500	15

*All reading are typical values at rated voltage

*Specifications are subject to change without notice

* Bearing system B: Two Ball Bearing

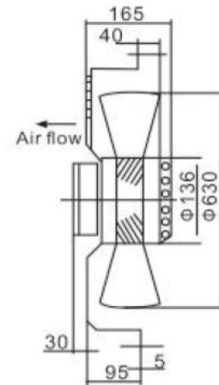
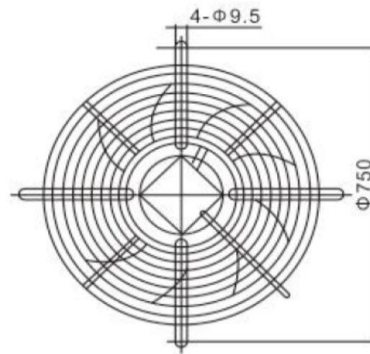
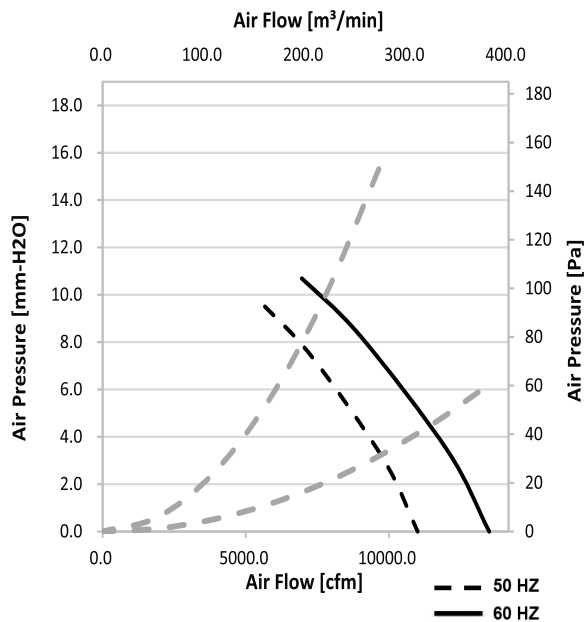

www.crownelectronics.com.tw



710

JGT Series

Size (尺寸) Φ 710 mm



General Specifications (一般規格)

- ★ Motor : Capacitor motor. ★ 馬達 : 交流電容式馬達
- ★ Guard : Steel ★ 材料 / 框 : 鋼網
- ★ Impeller : Metal SPCC ★ 材料 / 葉 : 鋼鐵
- ★ Bearing : Ball Bearing ★ 軸承 / 滾珠軸承
- ★ IPXX Rank : IP54 ★ 防水等級 : IP54

AC External Rotor (交流外轉子風機)

Major Characteristic Parameters

Model	Bearing System	Rated Voltage	Freq.	Input Power	Rated Speed	Maximum Air Flow		Weight
						m3/min	CFM	
Part NO.	B / S	VAC	Hz	WATT	RPM			Kg
JGT710B2H	B	380~420	50 / 60	616 / 1100	1300 / 1500	169.9 / 175.3	6000 / 6189	17
JGT710B4H	B	380~420	50 / 60	616 / 1100	1300 / 1500	169.9 / 175.3	6000 / 6189	17

*All reading are typical values at rated voltage

*Specifications are subject to change without notice

* Bearing system B: Two Ball Bearing

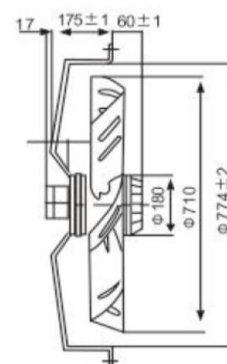
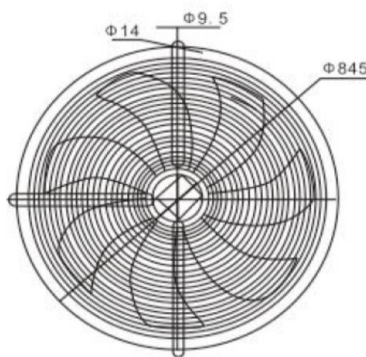
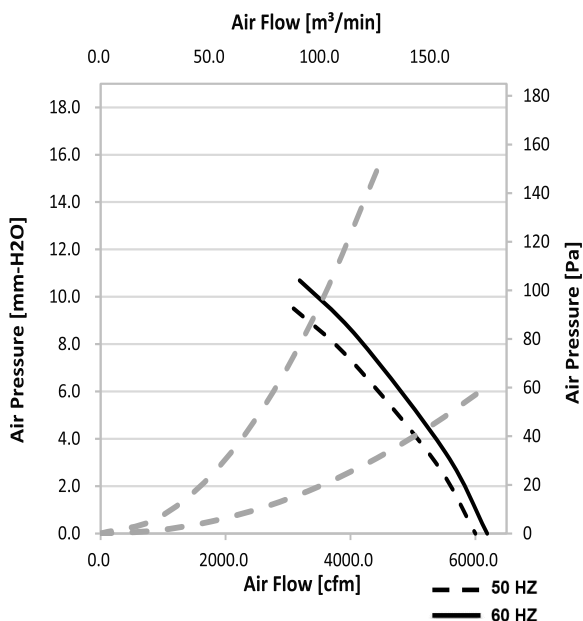

www.crownelectronics.com.tw



800 JGT Series

Size (尺寸) Φ 800 mm



General Specifications (一般規格)

- ★ Motor : Capacitor motor. ★ 馬達 : 交流電容式馬達
- ★ Guard : Steel ★ 材料 / 框 : 鋼網
- ★ Impeller : Metal SPCC ★ 材料 / 葉 : 鋼鐵
- ★ Bearing : Ball Bearing ★ 軸承 / 滾珠軸承
- ★ IPXX Rank : IP54 ★ 防水等級 : IP54

AC External Rotor (交流外轉子風機)

Major Characteristic Parameters

Model	Bearing System	Rated Voltage	Freq.	Input Power	Rated Speed	Maximum Air Flow		Weight
						m3/min	CFM	
Part NO.	B / S	VAC	Hz	WATT	RPM			Kg
JGT800B2H	B	380~420	50 / 60	1400 / 1400	940 / 940	629.8 / 373.2	22240 / 13180	20
JGT800B4H	B	380~420	50 / 60	1400 / 1400	940 / 940	629.8 / 373.2	22240 / 13180	20

*All reading are typical values at rated voltage

*Specifications are subject to change without notice

* Bearing system B: Two Ball Bearing

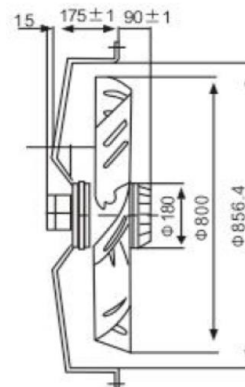
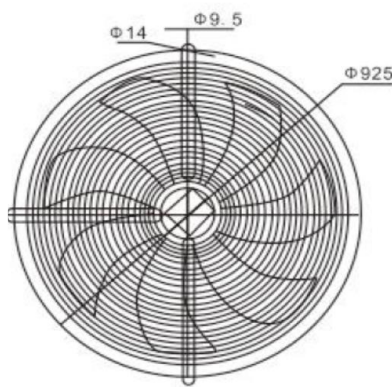
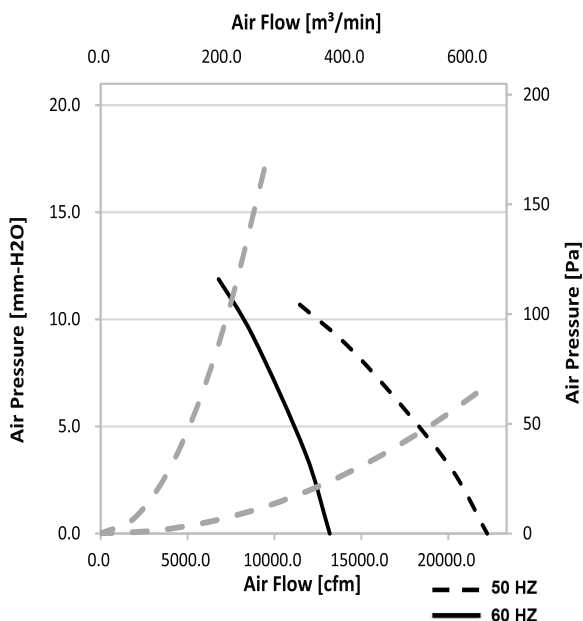

www.crownelectronics.com.tw

