

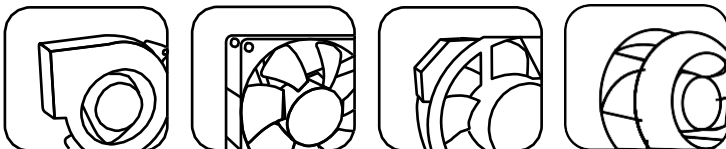

DC IMPELLER

CROWN PELECTRONICS













● ***PRODUCT FLOW LINE***



<http://www.crownelectronics.com.tw>

Ver.02

CROWN DC Impeller

Frame size \ Air flow (CFM)	200	250	300	400	500	600	700	800	900	1000
Ø133mm		91mm								
Ø175mm				68mm 74.4mm						
Ø190mm				74.4mm						
Ø200mm					74.4mm					
Ø220mm						74.4mm				
Ø225mm								74.4mm		
Ø250mm								74.4mm		
Ø280mm										74.4mm 
Ø310mm										74.4mm  74.4mm 

Application

Thermal exchange kit
Cooling fan
CNC machine cooling
Clean roon ventilator

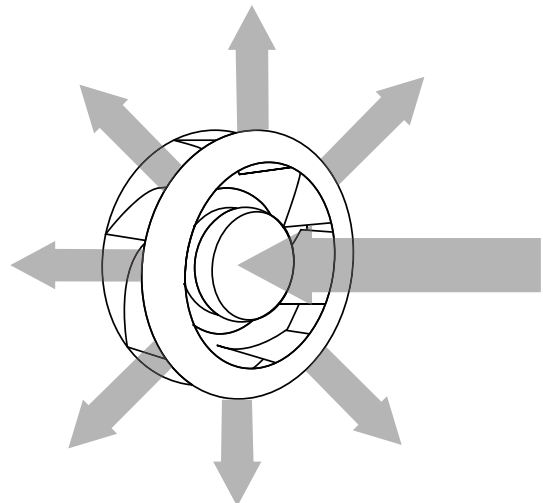
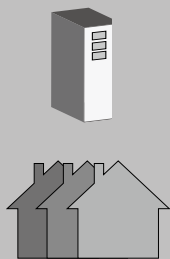

100

BGN Series

Size (尺寸) 100*100*25

General Specifications (一般規格)

Motor : DC Brushless DC motor.	馬達 / 直流單向無刷馬達
Frame : Plastic (94V-0)	材料 / 框 : 塑膠 (94V-0)
Impeller : Plastic (94V-0)	材料 / 葉 : 塑膠 (94V-0)
Bearing : Ball Bearing	軸承 / 滾珠軸承
Weight : 130 g	重量 / 130 克

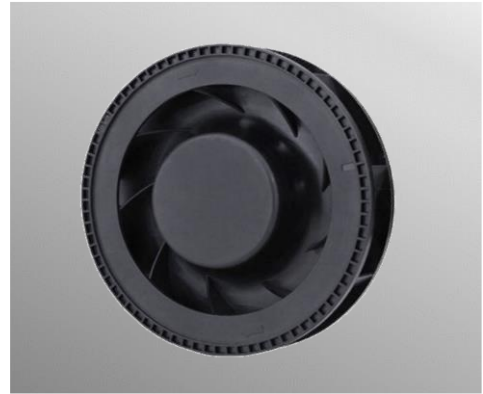

Major Characteristic Parameters (主要參數)

Model 機型	Bearing System 軸承	Rated Voltage 電壓	Operating Range 操作電壓	Rated Current 電流	Rated Speed 轉速	Maximum Air Flow 最大風量		Maximum Static Pressure 最大風壓		Sound Level 噪音	P-Q 曲線
Part NO.	B / F / S	V	V	A	RPM	m3/min	CFM	mm-H2O	in-H2O	dBA	NO.
BGN10025B24H	B	24	14.0~26.2	0.30	4300	71.00	42.00	222.00	0.89	53.0	(2)
BGN10025B24U	B	12	14.0~26.2	0.60	5300	93.00	55.00	371.00	1.49	58.0	(1)

*Function type is optional. (其它功能類型是可加選的) *All reading are typical values at rated voltage. (所有讀數均為額定電壓下測試的參數)
 * Bearing (軸承) B: Two Ball Bearing (滾珠) F: Fluid Bearing (液壓) S: Sleeve Bearing (合銅) *The P-Q NO. is counted from low CFM.(P-Q曲線區分,請從最小風量(1)往大的數)

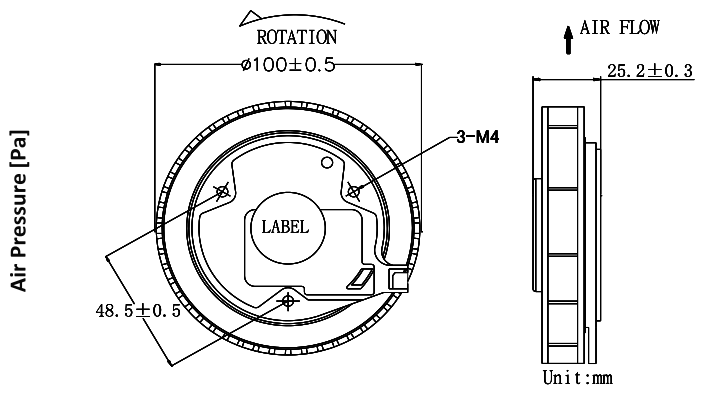
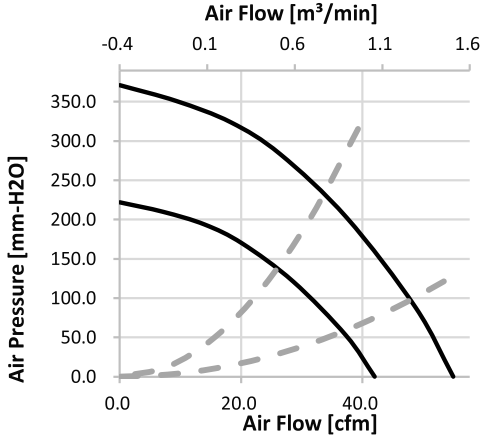

120

BGN Series

Size (尺寸) 120*120*25

General Specifications (一般規格)

Motor	: DC Brushless DC motor.	馬達 / 直流單向無刷馬達
Frame	: Plastic (94V-0)	材料 / 框: 塑膠 (94V-0)
Impeller	: Plastic (94V-0)	材料 / 葉: 塑膠 (94V-0)
Bearing	: Ball Bearing	軸承 / 滾珠軸承
Weight	: 180 g	重量 / 180 克

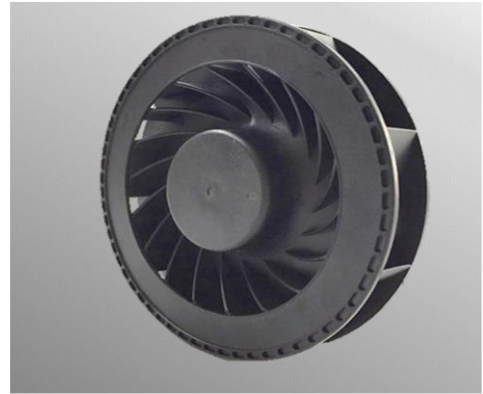

Major Characteristic Parameters (主要參數)

Model 機型	Bearing System 軸承	Rated Voltage 電壓	Operating Range 操作電壓	Rated Current 電流	Rated Speed 轉速	Maximum Air Flow 最大風量		Maximum Static Pressure 最大風壓		Sound Level 噪音	P-Q 曲線
Part NO.	B / F / S	V	V	A	RPM	m3/min	CFM	mm-H2O	in-H2O	dBA	NO.
BGN12025B12H	B	12	7.0~13.2	1.0	3500	1.84	65.11	19.28	0.76	54.7	(1)
BGN12025B12H	B	12	7.0~13.2	0.48	3500	1.84	65.11	19.28	0.76	54.7	(1)
BGN12025B12H	B	12	7.0~13.2	0.23	3500	1.84	65.11	19.28	0.76	54.7	(1)

*Function type is optional. (其它功能類型是可加選的) *All reading are typical values at rated voltage. (所有讀數均為額定電壓下測試的參數)
 * Bearing (軸承) B: Two Ball Bearing (滾珠) F: Fluid Bearing (液壓) S: Sleeve Bearing (合銅) *The P-Q NO. is counted from low CFM. (P-Q曲線區分,請從最小風量(1)往大的數)

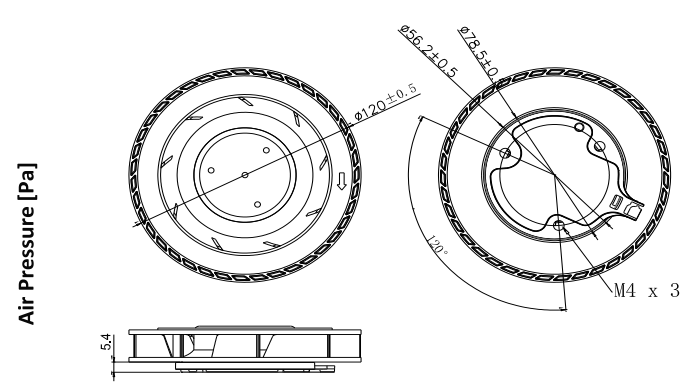
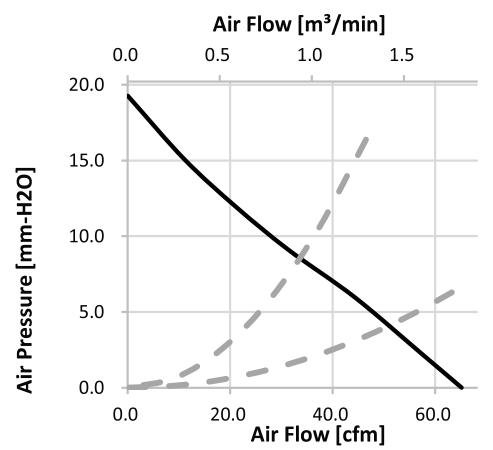

150

BGN Series

Size (尺寸) 150*150*35

General Specifications (一般規格)

Motor : DC Brushless DC motor.	馬達 / 直流單向無刷馬達
Frame : Aluminum	材料 / 框 : 鋁
Impeller : Plastic (94V-0)	材料 / 葉 : 塑膠 (94V-0)
Bearing : Ball Bearing	軸承 / 滾珠軸承
Weight : 330 g	重量 / 330 克

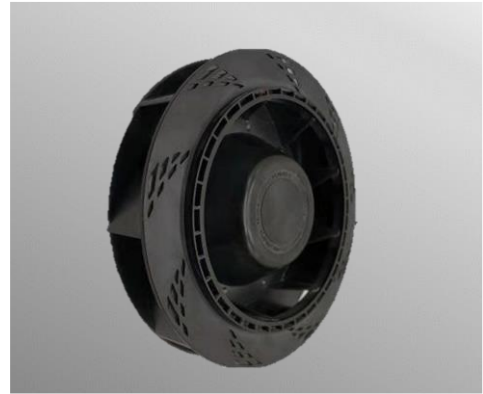

Major Characteristic Parameters (主要參數)

Model 機型	Bearing System 軸承	Rated Voltage 電壓	Operating Range 操作電壓	Rated Current 電流	Rated Speed 轉速	Maximum Air Flow 最大風量		Maximum Static Pressure 最大風壓		Sound Level 噪音	P-Q 曲線
Part NO.	B / F / S	V	V	A	RPM	m3/min	CFM	mm-H2O	In-H2O	dB(A)	NO.
BGN15035B24U	B	24	14.0~26.2	0.70	3500	3.94	139.00	32.20	1.27	61.0	(1)
BGN15035B48U	B	48	28.0~56.0	0.40	3500	3.94	139.00	32.20	1.27	61.0	(1)

*Function type is optional. (其它功能類型是可加選的) *All reading are typical values at rated voltage. (所有讀數均為額定電壓下測試的參數)
 * Bearing (軸承) B: Two Ball Bearing (滾珠) F: Fluid Bearing (液壓) S: Sleeve Bearing (合銅) *The P-Q NO. is counted from low CFM.(P-Q曲線區分,請從最小風量(1)往大的數)

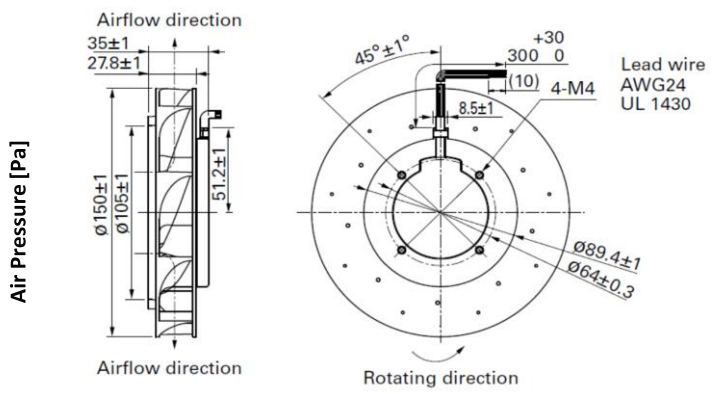
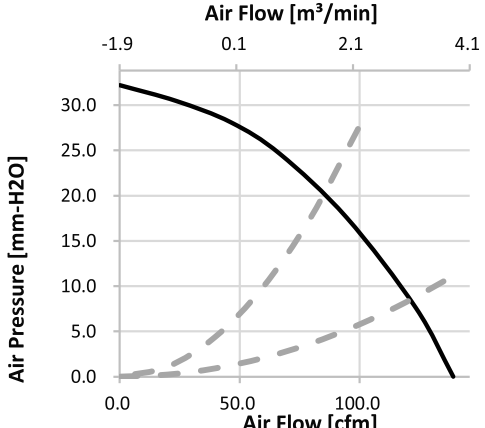

www.crownelectronics.com.tw





133

BGN series

mmx91mm

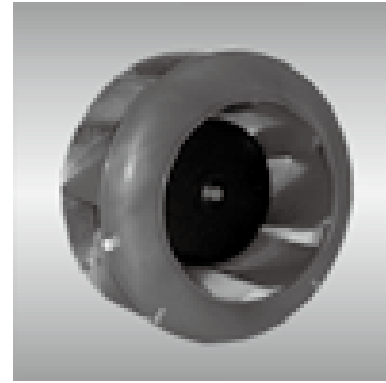

General Specifications

- Motor : 8 Poles brushless DC motor
- Frame & Impeller : Al die casting & plastic
- Storage temperature : -40°C to +75°C
- Operating temperature : -10°C to +70°C

Major Characteristic Parameters

Model	Bearing System	Rated Voltage	Operating Voltage Range	Rated Current	Rated Speed	Maximum Air Flow		Maximum Static Pressure		Sound Level	Weight
Part NO.	B / S / F	V	V	A	RPM	m ³ /min	CFM	mm-H ₂ O	In-H ₂ O	dBA	Kg
BGN13391B48U	Ball	48	36~56	1.3	4,500	7.00	247.5	41.5	1.63	70	0.74
BGN13391B48H	Ball	48	36~56	0.8	4,000	6.00	212.2	36.8	1.45	65	0.74
BGN13391B24H	Ball	24	18~28	1.6	4,000	6.00	212.2	36.8	1.45	65	0.74

*Bearing system B: Two Ball Bearing F: Fluid Bearing S: Sleeve Bearing

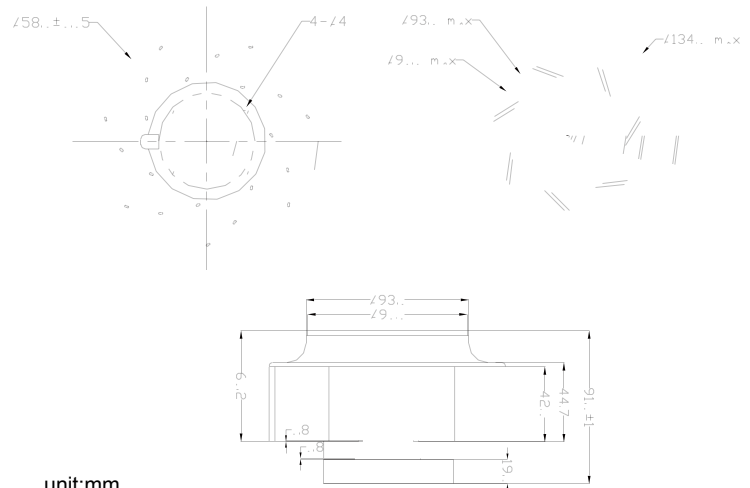
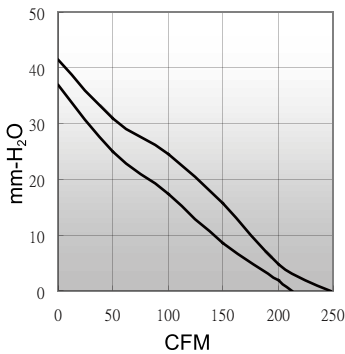

175

BGN Series

Size (尺寸) 175*175*69

General Specifications (一般規格)

Motor : DC Brushless DC motor.	馬達 / 直流單向無刷馬達
Frame : Aluminum	材料 / 框 : 鋁
Impeller : Plastic (94V-0)	材料 / 葉 : 塑膠 (94V-0)
Bearing : Ball Bearing	軸承 / 滾珠軸承
Weight : 1000 g	重量 / 1000 克



Major Characteristic Parameters (主要參數)

Model 機型	Bearing System 軸承	Rated Voltage 電壓	Operating Range 操作電壓	Rated Current 電流	Rated Speed 轉速	Maximum Air Flow 最大風量		Maximum Static Pressure 最大風壓		Sound Level 噪音	P-Q 曲線
Part NO.	B / F / S	V	V	A	RPM	m3/min	CFM	mm-H2O	In-H2O	dBA	NO.
BGN17569_12U	B	12	7.0~13.2	2.80	3100	8.84	312.04	37.24	1.47	64.0	(1)
BGN17569_24U	B	24	14.0~26.2	1.50	3100	8.84	312.04	37.24	1.47	64.0	(1)
BGN17569_48U	B	48	28.0~56.0	0.71	3100	8.84	312.04	37.24	1.47	64.0	(1)

*Function type is optional. (其它功能類型是可加選的) *All reading are typical values at rated voltage. (所有讀數均為額定電壓下測試的參數)
 * Bearing (軸承) B: Two Ball Bearing (滾珠) F: Fluid Bearing (液壓) S: Sleeve Bearing (合銅) *The P-Q NO. is counted from low CFM.(P-Q曲線區分,請從最小風量(1)往大的數)

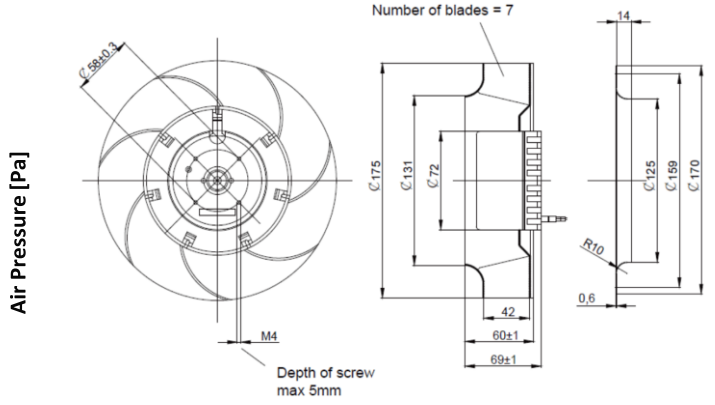
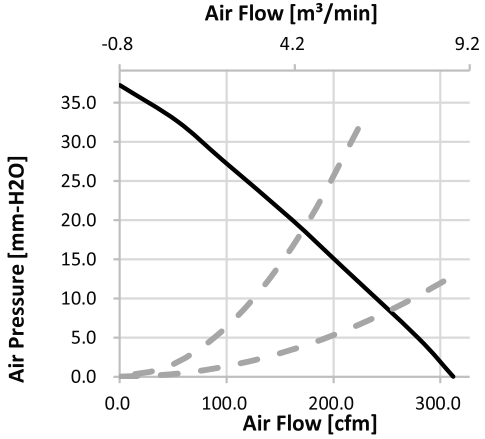

www.crownelectronics.com.tw



190

BGN Series

Size (尺寸) 190*190*69

General Specifications (一般規格)

Motor : DC Brushless DC motor.	馬達 / 直流單向無刷馬達
Frame : Aluminum	材料 / 框 : 鋁
Impeller : Metal SPCC	材料 / 葉 : 鋼鐵
Bearing : Ball Bearing	軸承 / 滾珠軸承
Weight : 1500 g	重量 / 1500 克



Major Characteristic Parameters (主要參數)

Model 機型	Bearing System 軸承	Rated Voltage 電壓	Operating Range 操作電壓	Rated Current 電流	Rated Speed 轉速	Maximum Air Flow 最大風量		Maximum Static Pressure 最大風壓		Sound Level 噪音	P-Q 曲線
Part NO.	B / F / S	V	V	A	RPM	m3/min	CFM	mm-H2O	In-H2O	dBA	NO.
BGN19069_24U	B	24	14.0~26.2	2.30	2900	10.68	377.00	50.51	1.99	70.0	(1)
BGN19069_48U	B	48	36.0~56.0	1.15	2900	10.68	377.00	50.51	1.99	70.0	(1)

*Function type is optional. (其它功能類型是可加選的) *All reading are typical values at rated voltage. (所有讀數均為額定電壓下測試的參數)
 * Bearing (軸承) B: Two Ball Bearing (滾珠) F: Fluid Bearing (液壓) S: Sleeve Bearing (合銅) *The P-Q NO. is counted from low CFM.(P-Q曲線區分,請從最小風量(1)往大的數)

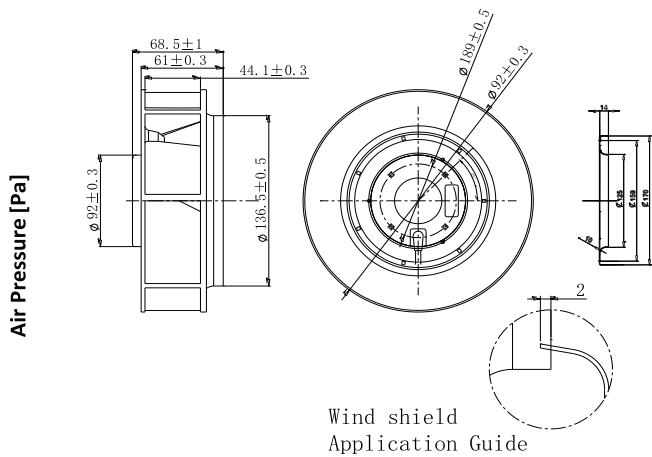
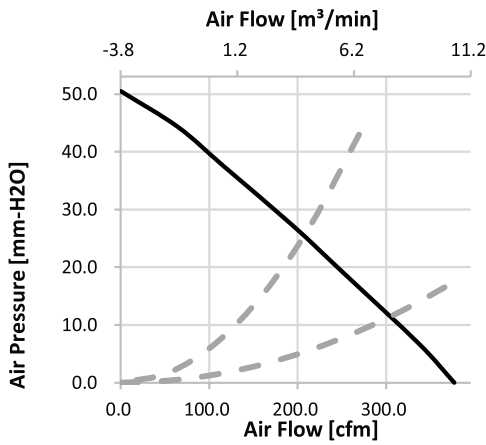

220

BGN Series

Size (尺寸) 220*220*71

General Specifications (一般規格)

Motor : DC Brushless DC motor.	馬達 / 直流單向無刷馬達
Frame : Aluminum	材料 / 框 : 鋁
Impeller : Plastic (94V-0)	材料 / 葉 : 塑膠 (94V-0)
Bearing : Ball Bearing	軸承 / 滾珠軸承
Weight : 1500 g	重量 / 1500 克



Major Characteristic Parameters (主要參數)

Model 機型	Bearing System 軸承	Rated Voltage 電壓	Operating Range 操作電壓	Rated Current 電流	Rated Speed 轉速	Maximum Air Flow 最大風量		Maximum Static Pressure 最大風壓		Sound Level 噪音	P-Q 曲線
Part NO.	B / F / S	V	V	A	RPM	m3/min	CFM	mm-H2O	In-H2O	dBA	NO.
BGN22071_24U	B	24	14.0~26.2	2.60	2400	13.83	488.36	38.27	1.51	67.0	(1)
BGN22071_48U	B	48	36.0~56.0	1.00	2400	13.83	488.36	38.27	1.51	67.0	(1)
BGN22071_12U	B	12	7.0~13.2	4.60	2400	13.83	488.36	38.27	1.51	67.0	(1)

*Function type is optional. (其它功能類型是可加選的) *All reading are typical values at rated voltage. (所有讀數均為額定電壓下測試的參數)
 * Bearing (軸承) B: Two Ball Bearing (滾珠) F: Fluid Bearing (液壓) S: Sleeve Bearing (合銅) *The P-Q NO. is counted from low CFM.(P-Q曲線區分,請從最小風量(1)往大的數)

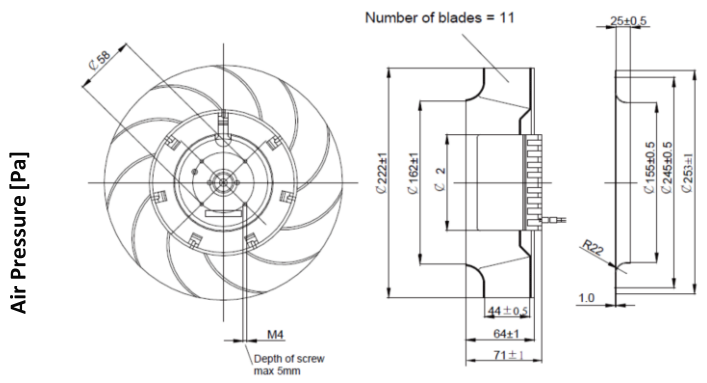
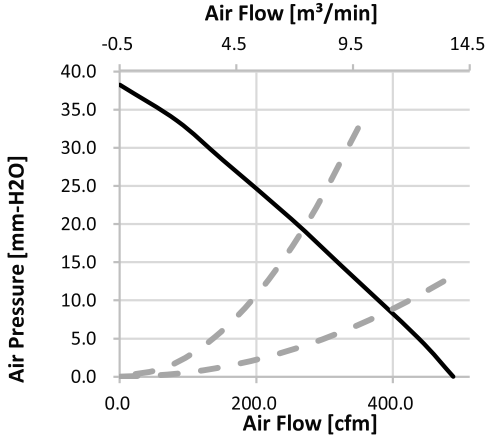

225 BGN Series

Size (尺寸) 225*225*99

General Specifications (一般規格)

Motor : DC Brushless DC motor. 馬達 / 直流單向無刷馬達
 Frame : Aluminum 材料 / 框 : 鋁
 Impeller : Plastic (94V-0) 材料 / 葉 : 塑膠 (94V-0)
 Bearing : Ball Bearing 軸承 / 滾珠軸承
 Weight : 2200 g 重量 / 2200 克



Major Characteristic Parameters (主要參數)

Model 機型	Bearing System 軸承	Rated Voltage 電壓	Operating Range 操作電壓	Rated Current 電流	Rated Speed 轉速	Maximum Air Flow 最大風量		Maximum Static Pressure 最大風壓		Sound Level 噪音	P-Q 曲線
Part NO.	B / F / S	V	V	A	RPM	m3/min	CFM	mm-H2O	In-H2O	dBA	NO.
BGN22599_24U	B	24	14.0~26.2	4.20	2750	18.76	662.36	48.57	1.91	72.0	(1)
BGN22599_48U	B	48	36.0~56.0	2.10	2750	18.76	662.36	48.57	1.91	72.0	(1)

*Function type is optional. (其它功能類型是可加選的) *All reading are typical values at rated voltage. (所有讀數均為額定電壓下測試的參數)
 * Bearing (軸承) B: Two Ball Bearing (滾珠) F: Fluid Bearing (液壓) S: Sleeve Bearing (合銅) *The P-Q NO. is counted from low CFM.(P-Q曲線區分,請從最小風量(1)往大的數)

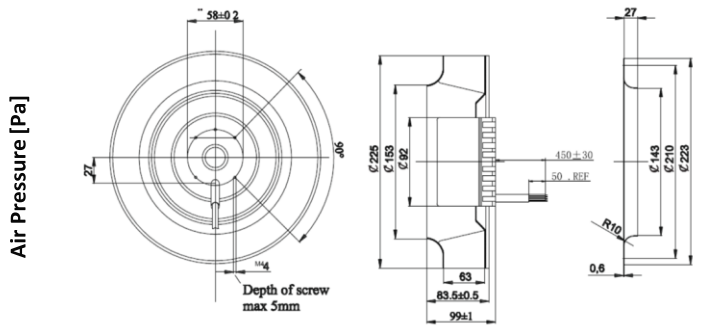
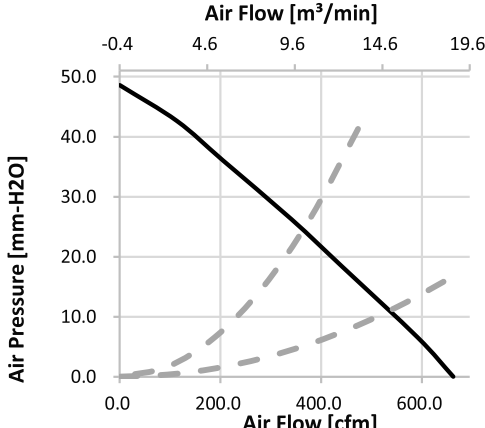

250 BGN Series

Size (尺寸) 250*250*99

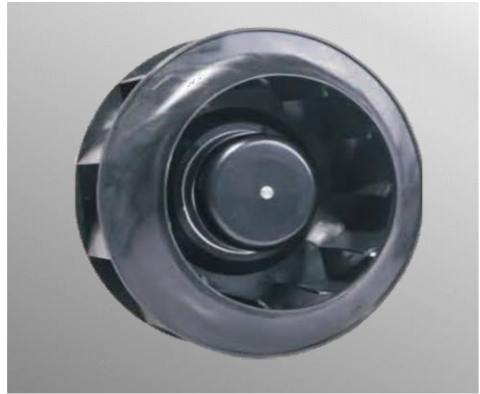

General Specifications (一般規格)

Motor : DC Brushless DC motor.	馬達 / 直流單向無刷馬達
Frame : Aluminum	材料 / 框 : 鋁
Impeller : Plastic (94V-0)	材料 / 葉 : 塑膠 (94V-0)
Bearing : Ball Bearing	軸承 / 滾珠軸承
Weight : 2800 g	重量 / 2800 克

Major Characteristic Parameters (主要參數)

Model 機型	Bearing System 軸承	Rated Voltage 電壓	Operating Range 操作電壓	Rated Current 電流	Rated Speed 轉速	Maximum Air Flow 最大風量		Maximum Static Pressure 最大風壓		Sound Level 噪音	P-Q 曲線
Part NO.	B / F / S	V	V	A	RPM	m3/min	CFM	mm-H ₂ O	in-H ₂ O	dBA	NO.
BGN25099B24U	B	24	14~26.2	5.70	2750	24.85	877.54	60.10	2.37	75.0	(1)
BGN25099B48U	B	48	28~56	3.00	2750	24.85	877.54	60.10	2.37	75.0	(1)

*Function type is optional. (其它功能類型是可加選的) *All reading are typical values at rated voltage. (所有讀數均為額定電壓下測試的參數)
 * Bearing (軸承) B: Two Ball Bearing (滾珠) F: Fluid Bearing (液壓) S: Sleeve Bearing (合銅) *The P-Q NO. is counted from low CFM.(P-Q曲線區分,請從最小風量(1)往大的數)

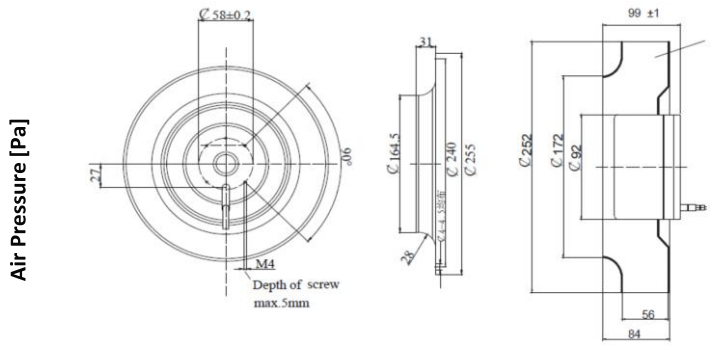
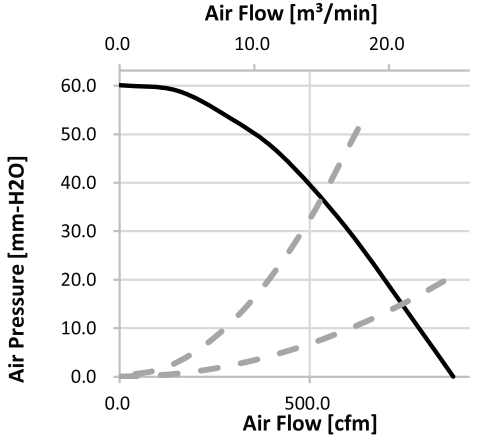

∅280 BGN series

mmx105mm

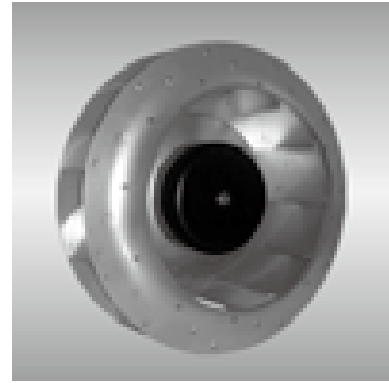

General Specifications

- Motor : 8 Poles brushless DC motor
- Frame & Impeller : Al die casting & plastic
- Storage temperature : -40°C to +75°C
- Operating temperature : -10°C to +70°C

Major Characteristic Parameters

Model	Bearing System	Rated Voltage	Operating Voltage Range	Rated Current	Rated Speed	Maximum Air Flow		Maximum Static Pressure		Sound Level	Weight
Part NO.	B / S / F	V	V	A	RPM	m ³ /min	CFM	mm-H ₂ O	In-H ₂ O	dBA	Kg
BGN280105B48U	B	48	36~56	2.3	2,200	24.16	853	61.5	2.42	74	2.85

*Bearing system B: Two Ball Bearing F: Fluid Bearing S: Sleeve Bearing

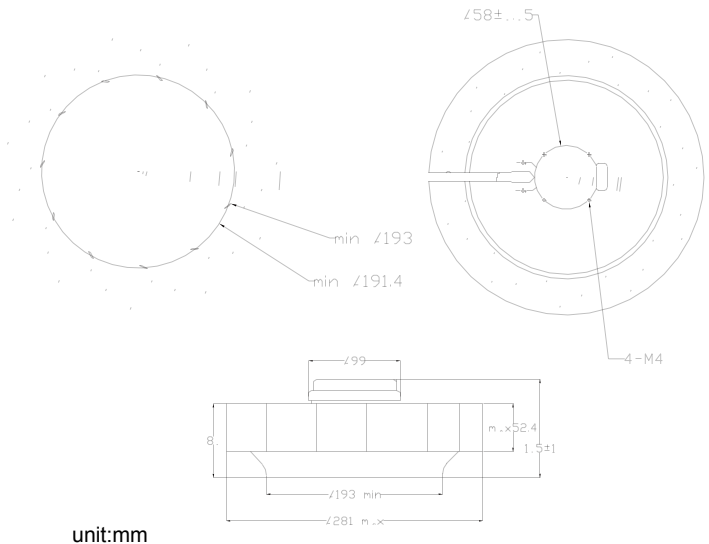
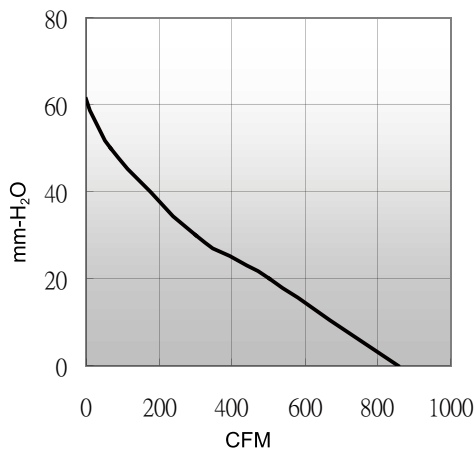

∅ 280 BGN series

mmx135mm

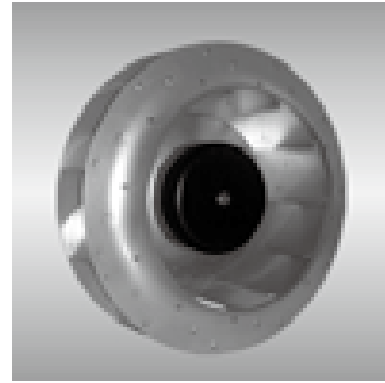

General Specifications

- Motor : 8 Poles brushless DC motor
- Frame & Impeller : Al die casting & plastic
- Storage temperature : -40°C to +75°C
- Operating temperature : -10°C to +70°C

Major Characteristic Parameters

Model	Bearing System	Rated Voltage	Operating Voltage Range	Rated Current	Rated Speed	Maximum Air Flow		Maximum Static Pressure		Sound Level	Weight
Part NO.	B / S / F	V	V	A	RPM	m ³ /min	CFM	mm-H ₂ O	In-H ₂ O	dBA	Kg
BGN280135B48U	B	48	36.0~56.0	2.4	1,700	28.04	990	40.5	1.59	72	3.3

*Bearing system B: Two Ball Bearing F: Fluid Bearing S: Sleeve Bearing

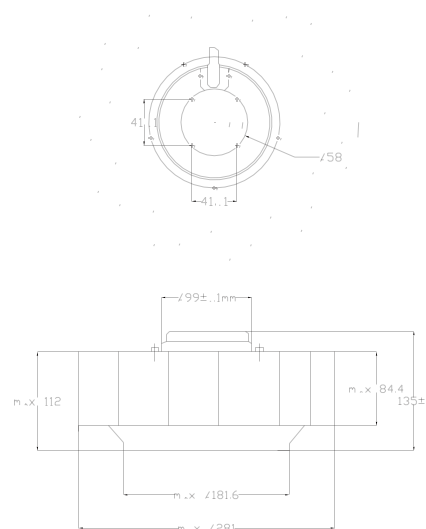
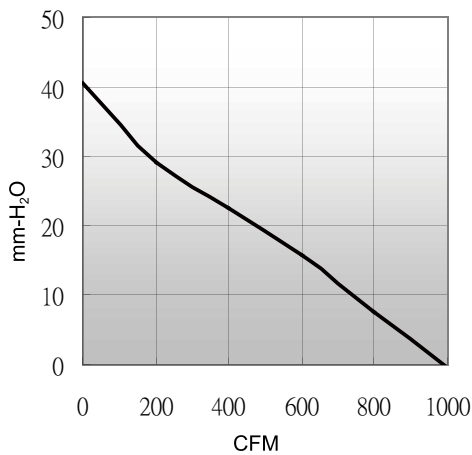

unit:mm

310

BGN Series

Size (尺寸) 280*280*99

General Specifications (一般規格)

Motor	: DC Brushless DC motor.	馬達 / 直流單向無刷馬達
Frame	: Aluminum	材料 / 框 : 鋁
Impeller	: Metal SPCC	材料 / 葉 : 鋼鐵
Bearing	: Ball Bearing	軸承 / 滾珠軸承
Weight	: 300 g	重量 / 300 克



Major Characteristic Parameters (主要參數)

Model 機型	Bearing System 軸承	Rated Voltage 電壓	Operating Range 操作電壓	Rated Current 電流	Rated Speed 轉速	Maximum Air Flow 最大風量		Maximum Static Pressure 最大風壓		Sound Level 噪音	P-Q 曲線
Part NO.	B / F / S	V	V	A	RPM	m3/min	CFM	mm-H2O	in-H2O	dBA	NO.
BGN28099B24H	B	24	14.0~26.2	3.80	1600	28.15	994.12	14.65	0.58	62.0	(2)
BGN28099B48H	B	48	28.0~56.0	1.90	1600	28.15	994.12	14.65	0.58	62.0	(2)
BGN28099B24U	B	24	14.0~26.2	5.00	1900	34.49	1218.00	22.09	0.87	66.0	(1)
BGN28099B48U	B	48	28.0~56.0	2.50	1900	34.49	1218.00	22.09	0.87	66.0	(1)

*Function type is optional. (其它功能類型是可加選的)

*All reading are typical values at rated voltage. (所有讀數均為額定電壓下測試的參數)

* Bearing (軸承) B: Two Ball Bearing (滾珠) F: Fluid Bearing (液壓) S: Sleeve Bearing (合銅)

*The P-Q NO. is counted from low CFM. (P-Q曲線區分,請從最小風量(1)往大的數)

